

Stratomaster E2

ENGINE MONITORING SYSTEM

OPERATOR'S MANUAL

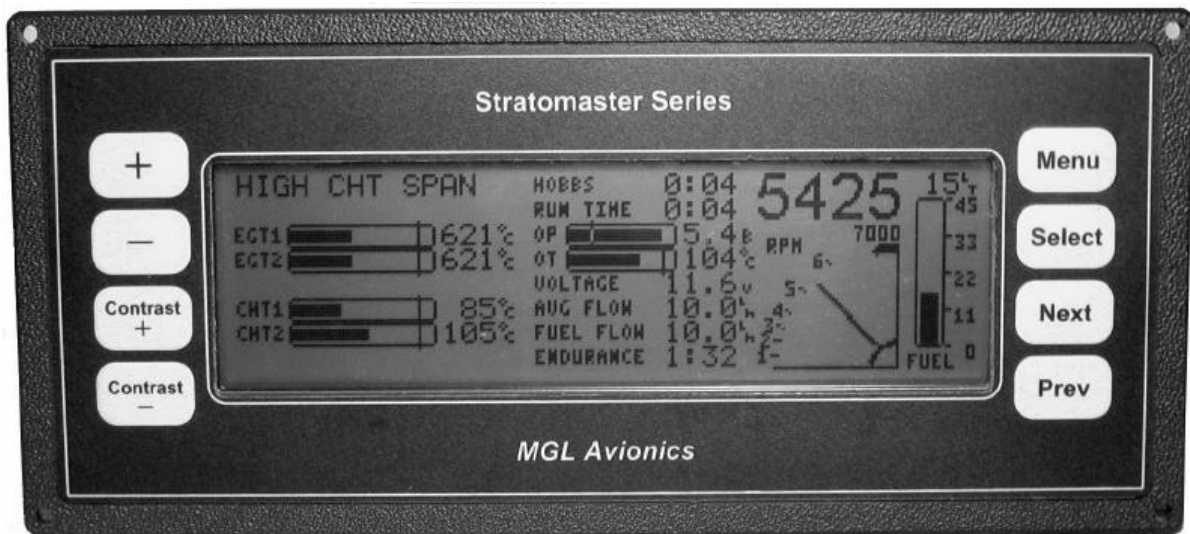

Release: 020826M

MGL Avionics
P O Box 286
Sundowner 2161
South Africa

Email: rainier@iafrica.com
Web: <http://users.iafrica.com/r/ra/rainier/strato.htm>

Table of Contents

Introduction.....	2
Disclaimer	2
Warranty	2
What Does It Do?.....	3
How it works.....	3
Installation.....	6
Power Supply	6
External Temperature Sensor.....	7
Alarm Indicator Lamp.....	7
Alarm Audio Output.....	8
AirTalk Link	9
Connecting the RDAC Unit.....	9
RDAC thermocouple inputs	9
Fuel-Flow Sender Installation	11
Recommended procedure to calibrate the fuel flow sender:	12
Using other makes of Flow Senders	13
Disclaimer.....	13
Note to Pilots.....	13
Connecting a Fuel-Level Sender	14
Connecting the Rev Counter	15
Typical Installation Examples	16
Rotax 503	16
Rotax 582.....	16
Rotax 912	17
Using the System	18
Understanding the Display.....	18
EGT Readings.....	18
Lean Mode	19
Cruise Mode	19
CHT Readings.....	19
Water Temperature	20
Oil Temperature / Pressure graphs.....	20
Fuel Level Display.....	20
Rev Counter	20
Hobbs Meter.....	20
Maintenance Timer.....	20
Ambient Temperature	20
Input Voltage	21
Fuel Flow and Fuel Totalizer.....	21
Estimated Endurance.....	21
The Menu System.....	21
Resetting the Trip-Timer	22
Resetting the Fuel Totalizer	22
User Preferences	22
Alarm Conditions.....	22
System Configuration	24
Device Setup - What shall we measure today?	24
Engine Quick Select Menu.....	24
Sender Setup Menu	27
Ambient Temperature Sender.....	28
Fuel Flow Sender	29
Fuel Level Sender	29
Fuel Level Sender Calibration.....	29
Range Setup - Maximum Limits.....	30

Alarm Setup - Abnormal Readings	30
Disabling Individual Alarms	31
User Preferences - Personal Tastes.....	31
Technical Setup	31
Technical Specifications.....	32

INTRODUCTION

The *Stratomaster E2* Engine Monitoring System (EMS) is a digital instrument designed to monitor and display various operating parameters of engines used in small aircraft catering for a wide range of engines from single cylinder two-strokes to four cylinder four-strokes.

This document describes installation details and full functional operation of the instrument.

DISCLAIMER

MGL Avionics will not be liable for technical or editorial errors or omissions contained herein, nor for any damages resulting from the furnishing, performance or use of this material.

MGL Avionics will not be liable for incidental or consequential damages resulting from the performance or use of the *Stratomaster E2* instrument or associated measurement probes.

WARRANTY

The *Stratomaster E2* and *RDAC IV* instruments are guaranteed against faulty workmanship on the part of *MGL Avionics* for a period of 12 months from date of purchase. *MGL Avionics* may at their discretion, decide to either repair or replace the instrument. *MGL Avionics* will provide free labour and parts. Courier costs and postage costs will be for the account of the purchaser.

Please note: Certain parts are subject to breakage by misuse or external influences that cannot be covered by any warranty.

In particular the following possible damages are excluded:

- LCD display – glass cracked due to mechanical damage or freezing of the liquid crystal. The LCD must not be exposed to temperatures below –20 degrees Celsius (-4 degrees Fahrenheit) or above +80 degrees Celsius (176 degrees Fahrenheit).
- Any damage due to unusual events e.g. aircraft crashes, hard landings, dropping the instrument, excessive G forces, excessive vibration.
- Exposing the instrument to incorrect power supply voltages, such as connecting the instrument to mains power supply, any voltage in excess of 30 volts DC, and any AC voltage.
- Connection of unqualified or incorrect devices. Please contact us before you connect anything unusual to this instrument.
- Destruction of the air-talk link due to connecting the unit to PC's with unconnected earth leads or leaky power supplies.
- Damage due to excessive static discharge.
- Damage due to lightning strike.

Any signs of opening the instrument or tampering with any of the internal parts will invalidate the warranty.

MGL Avionics endeavours to repair any faulty unit whether inside or outside of the warranty period speedily and at the lowest possible cost. Your first stop in case of a malfunction should be the dealer where you bought the instrument. It may be possible to repair your instrument without it having to be shipped to us.

WHAT DOES IT DO?

The *Stratomaster E2* continuously monitors and displays the following measurements on a large, graphic liquid-crystal display providing excellent viewing characteristics in direct sunlight or poorly lit conditions:

- Up to four EGT/CHT thermocouple inputs
- Two NTC (Negative Temperature Coefficient) inputs (Eg: CHT or water temperature)
- Oil temperature and oil pressure inputs
- Engine revs
- Remaining fuel
- Fuel flow (burn rate)
- Endurance (if fuel flow option installed)
- Ambient temperature
- Power supply voltage
- Presetable Hobbs meter (total engine running time)
- Maintenance count-down timer
- Resetable fuel totalizer (with average fuel consumption)

A comprehensive alarm system provides instant indication of any of the following alarm conditions:

- High engine revs (after presetable delay)
- High EGT and CHT
- High EGT and CHT differences between cylinders
- High water temperature
- High oil temperature
- Low oil pressure
- Low fuel
- Low estimated endurance

In addition, the *Stratomaster E2* provides:

- *Lean mode* facility to provide for optimum fuel mixture adjustments
- *Cruise mode* facility to provide instant identification of changing EGT trends
- Simple, yet comprehensive configuration options via a menu system
- Flight log (black box recorder) of all engine readings allowing the last 15 to 60 minutes of flight data to be stored. Data can be uploaded to a PC for analysis via standard Air-Talk link interface (with optional cable and PC software). Recording time depends on activity and rate of change of monitored engine data.

HOW IT WORKS

The *Stratomaster E2* is based around a fully integrated state-of-the-art microprocessor device providing a powerful, high-speed computer capable of performing thousands of operations and decisions in fractions of a second. This computer continuously monitors a host of engine parameters, displaying the results on a large, graphic, liquid-crystal display.

The *Stratomaster E2* interfaces to your engine through a separate *RDAC IV* Remote Data Acquisition Computer which is physically mounted right at the engine where your probes are connected. This ensures that all wiring is kept to a minimum, greatly reducing installation time and providing excellent noise immunity. The various measurement probes are connected to the relevant inputs of the *RDAC*

IV where they are continuously monitored and transmitted to the main display unit via a single three-core cable.

The *Stratmaster E2* is highly configurable, allowing it to interpret and display readings from a wide variety of probe types as well as engine parameter configurations. Built-in standard engine defaults are available for instant recall in order to simplify programming during system setup.

Temperatures (EGT/CHT/water/oil) are displayed as bar-graphs as well as numerically down to one degree resolution allowing both relative and absolute temperatures to be easily seen even with only a brief glance.

Engine revs can be measured from a variety of sources from an engine tachometer output to a simple inductive pickup on both two and four-stroke engines.

Fuel level (remaining in tank) can be measured directly using a standard automotive fuel level sender (float type). A special tank calibration procedure allows the *E2* to "recognise" and compensate for odd tank shapes and thus always provide an accurate readout of remaining fuel.

If the optional fuel-flow sender is installed, a host of further possibilities become available. Fuel level can be calculated by continuously subtracting actual fuel used from an initial amount set when the tank was filled. This method of fuel level measurement is sometimes preferable to using a fuel level sender, as it is independent of any motion of fuel in the tank, which may upset the float mechanism and produce inaccurate readings. (Level readings are averaged in order to reduce such errors).

Knowing both fuel flow (burn-rate) and remaining fuel level, an instantaneous estimate of endurance (time remaining until fuel runs out) can be displayed. Fuel management becomes a snap way before a low-fuel condition becomes a problem.

A resettable fuel totalizer continuously tallies fuel-flow allowing an accurate total of fuel used as well as average fuel-flow, to be displayed.

A special *Lean Mode* allows fuel mixture to be optimised by automatically detecting the peak EGT readings of each cylinder as the mixture is leaned.

A *Cruise Mode* shows EGT and CHT readings as relative to the cruise mode setting allowing immediate indication of changing trends.

The *Stratmaster E2* continuously monitors and displays all readings and activates an alarm if any of the user-selectable alarm conditions are exceeded. Undedicated alarm relay contacts allow an external alarm lamp or buzzer to be flashed at 1Hz for the duration of the alarm or until any key is pressed. During the alarm condition, the *E2* displays the reason for the alarm (Eg: FUEL LOW") and the relevant graph or reading is blinked to highlight the problem.

The *Stratmaster E2* maintains a continuous flight log (black-box-recorder) of all readings every few seconds while the engine is running allowing typically up to the last hour of readings to be uploaded to a PC for analysis.

INSTALLATION

The following pages show the recommended connections for installation of your *Stratmaster E2*. Proceed with your installation according to your individual requirements.

The *Stratmaster E2* display panel can be mounted in any suitable position in your cockpit panel. Although display viewing-angle is excellent both vertically and horizontally, for best results it is recommended that the display be viewed as directly as possible. Vertical viewing angles are somewhat better than horizontal.

The *Stratmaster E2* shares its rear panel with similar instruments in the *Stratmaster Series* so not all connections or ports will be fitted (Eg: There is no pitot tube on the *Stratmaster E2*). All connections available on the *Stratmaster E2* will be described in this document.

POWER SUPPLY

The *Stratmaster E2* requires a power supply voltage anywhere from 8V to 28V DC (typically a 12V battery fitted to your aircraft). Current consumption is very low at about 60-80 mA without display

It is recommended that a power-switch and 1.5A slow-blow fuse be fitted in the supply line connected as shown below
backlighting and in the region of 280 mA with backlight. This current consumption includes the power requirements of the *RDAC IV* unit.

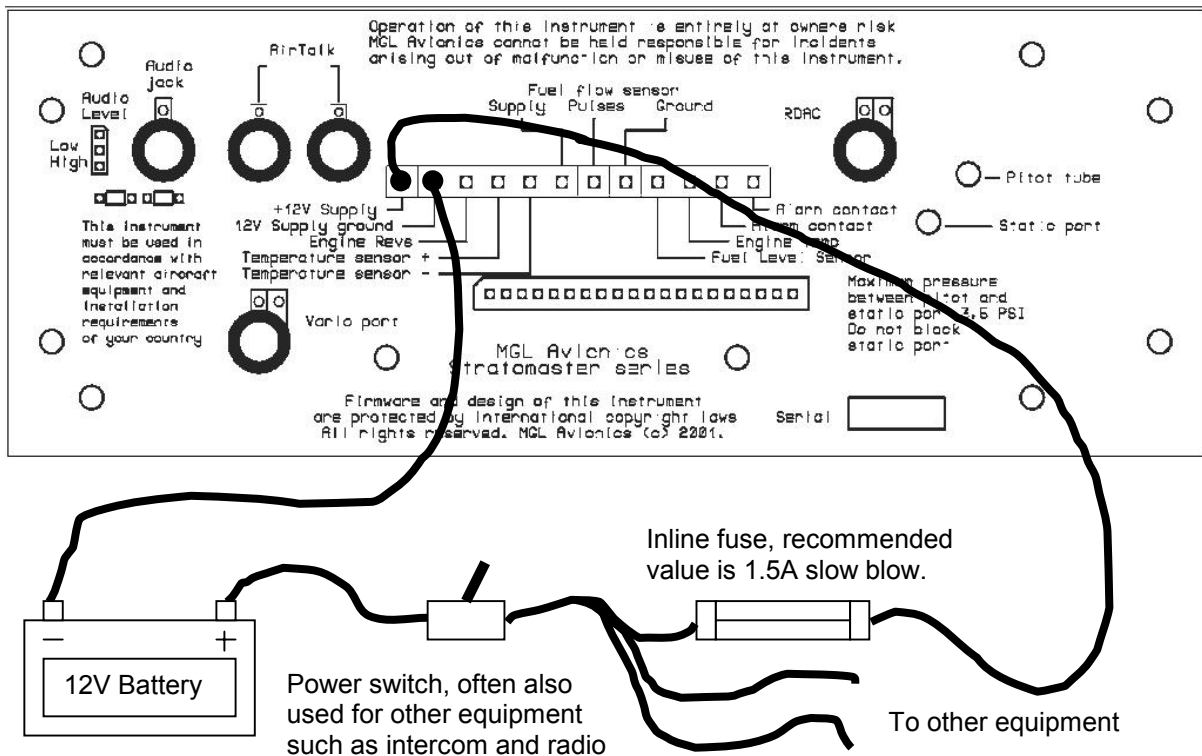

Generally it is not required to fit any form of power supply filters or surge suppressers as the *Stratmaster E2* includes the required protection devices. External power line filters or surge protectors should only be considered in very unusual conditions.

Please note: If you set the display backlight mode to “auto”, the display backlight will be switched off automatically after five minutes of no activity to conserve power. The display backlight will remain switched on if engine revs are detected. You can select backlight modes under the *User Preferences* menu (see page 29).

EXTERNAL TEMPERATURE SENSOR

The Stratmaster Flight includes a precision semiconductor temperature probe. It is recommended that you install it as shown above. The **RED** wire connects to the “Temperature sensor +” terminal. The remaining wire may be **GREEN**, **BLUE** or **BLACK**. This wire connects to the “Temperature sensor -” terminal.

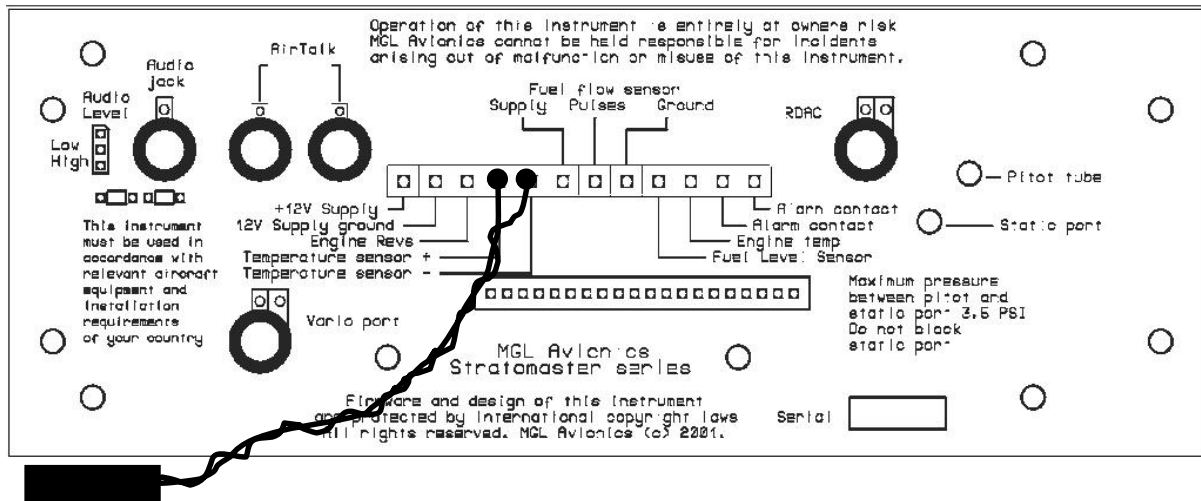

The probe head itself should be mounted using suitable means outside of the instrument pod or aircraft if a closed cockpit aircraft is used. The probe should be placed in the shadow of the pod or aircraft or in a place where sunlight cannot heat the probe. Also ensure that engine heat or exhaust gases cannot heat the probe at any time.

The twisted cable can be extended should this be required. In this case please use a similar cable type and continue the twist for the length of the cable.

Should you choose not to use the probe, please disable the “Has External Temp” in the *Device Setup Menu*. In this case the unit will use the internal temperature probe of the *RDAC* unit. Due to self-heating of the unit this may lead to incorrect ambient temperature readings. It is therefore recommended that you install the external temperature probe.

Should you require a suitable replacement probe, it can be obtained from *MGL Avionics* at reasonable cost or you can make up your own probe. In this case obtain a National Semiconductor Temperature Sensor type LM335 in a TO92 package.

ALARM INDICATOR LAMP

The *Stratmaster E2* provides an uncommitted relay contact (i.e. not connected to anything) that opens and closes once a second in the case of an active alarm. This can be used to switch an indicator panel lamp or a small buzzer.

The contact is rated for a maximum current of 0.5 amperes (500 mA) at 50 V. **Exceeding this specification could permanently damage the internal reed relay contact.** We suggest using a 12V / 1W indicator lamp such as can be found in many automotive parts supply shops. These indicators (called pilot lights) come in many colours, sizes and shapes.

Please note that the *Stratmaster E2* will close the alarm contact briefly every time the unit is switched on. This is intended to provide a means of checking that the alarm is functional during pre-take-off checks.

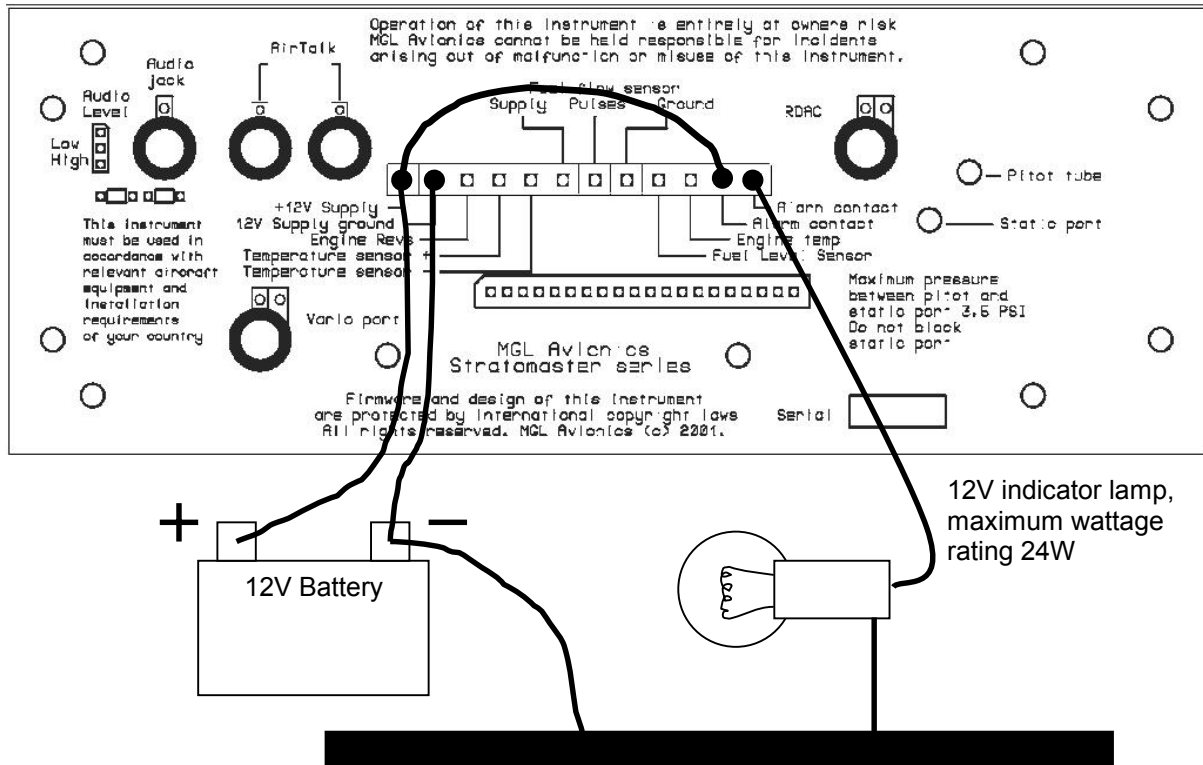

Please note: The drawing above leaves out the switch between the (+) terminal of the battery and the *Stratmaster E2* unit for the sake of clarity.

ALARM AUDIO OUTPUT

In addition to the alarm output contact described in the previous section, you can connect either a speaker or an intercom system to the Stratmaster Extreme. In this case an alarm tone will sound once a second for half a second whenever an alarm is active.

In case you connect a speaker, you should set the audio level to “high” by bridging the relevant link position. Should you want to connect to an intercom system that has an external audio input, set the audio level to “low”.

Note: Please ensure that your intercom system will mute any external audio should radio transmissions be received. It may be illegal in your country to use any other system.

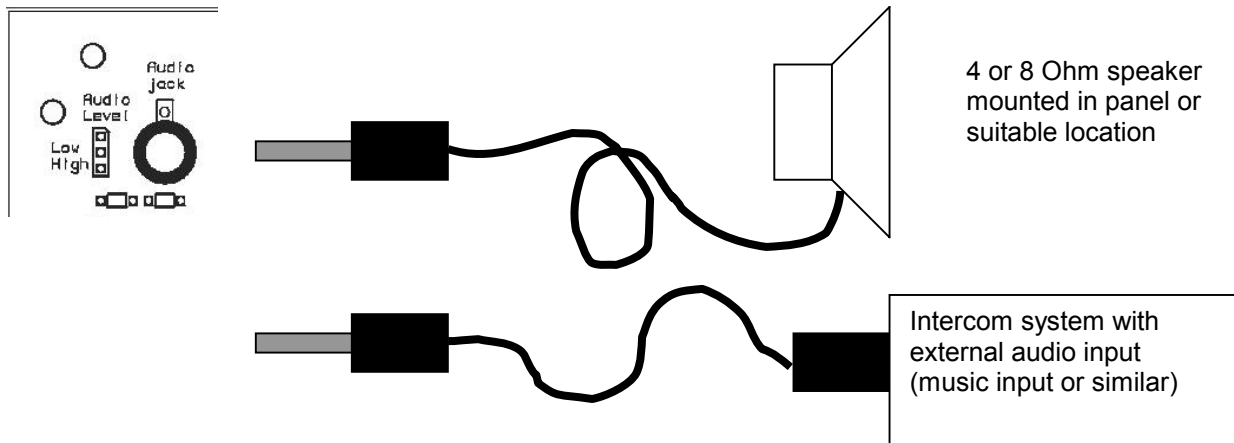

AIR TALK LINK

Two RCA audio plugs provide for connection of the *Stratmaster E2* to an *AirTalk* local area network. The plugs are paralleled to allow for daisy-chaining the instrument to other *AirTalk* compatible devices. The *Stratmaster E2* uses the *AirTalk* link for connection to a PC or laptop via a suitable cable and software (optional extra from *MGL Avionics*) to allow the flight recorder data to be retrieved for analysis.

CONNECTING THE RDAC UNIT

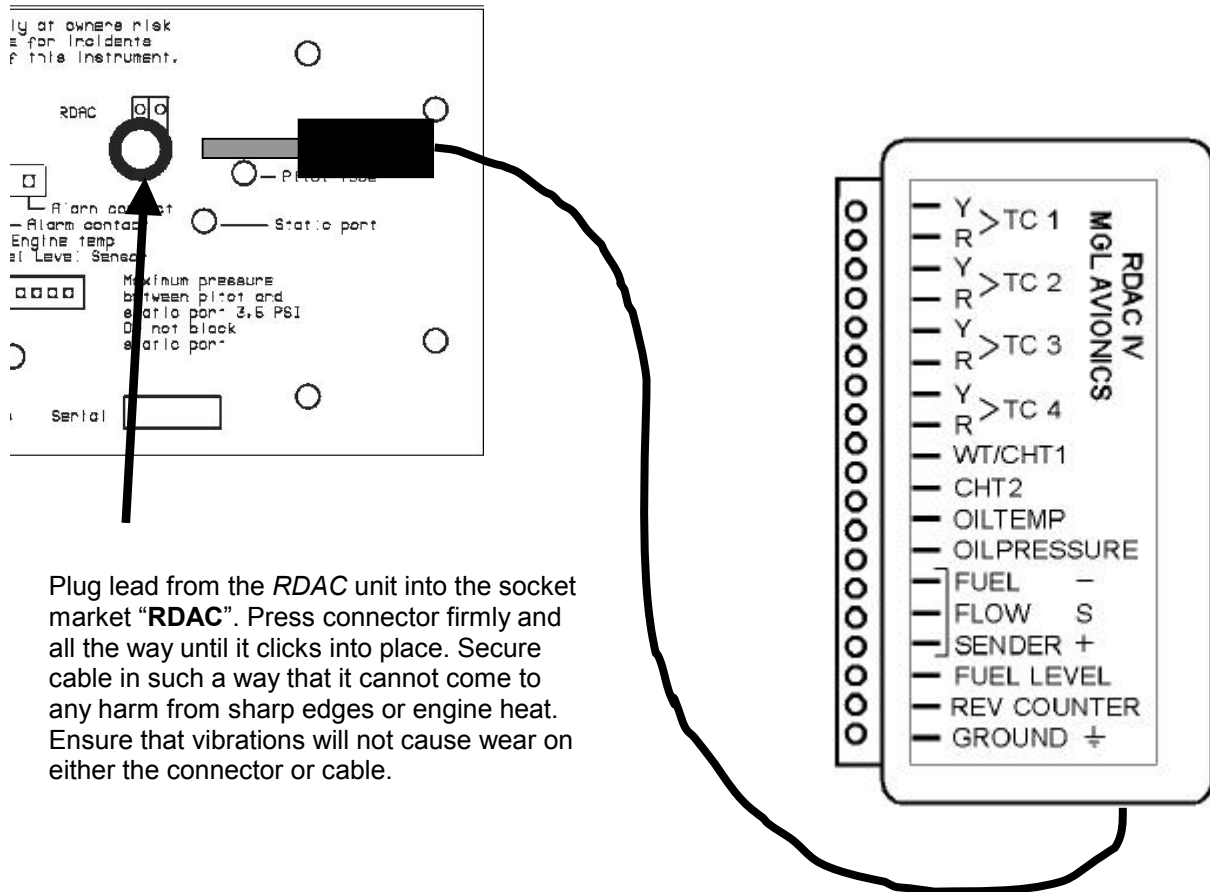

Plug lead from the *RDAC* unit into the socket marked “**RDAC**”. Press connector firmly and all the way until it clicks into place. Secure cable in such a way that it cannot come to any harm from sharp edges or engine heat. Ensure that vibrations will not cause wear on either the connector or cable.

RDAC THERMOCOUPLE INPUTS

The *RDAC IV* provides four thermocouple inputs for use with EGT and CHT probes. Both K as well as J-type probes can be used. K-types are used for EGT probes and while most CHT probes are also K-types, some makes of CHT probes are J-type. The probe type selection is done in the *Device Setup Menu (Sender Setup)*. Incorrect selection will lead to incorrect temperature display.

The *RDAC IV* will accept both grounded and isolated thermocouple probes. Your only consideration in case of the more common grounded configurations is that you need to ensure that the thermocouple mounting position (Exhaust flange, etc) is at the same electrical potential as the negative supply line of the *Stratmaster E2* (normally the – (minus) of the battery). The *RDAC* unit has an earth point marked “**GROUND**” that you should connect to the engine block via a short cable.

Probe usage depends on your setup of the *Stratmaster E2*. Some typical common selections of thermocouple probe usage include:

- 1xEGT, 2xCHT Rotax 447
- 2xEGT, 2xCHT Rotax 503, 582, VW
- 2xEGT Rotax 582, 912, 914
- 4xEGT Rotax 912, 914 (in addition to two NTC CHT channels)

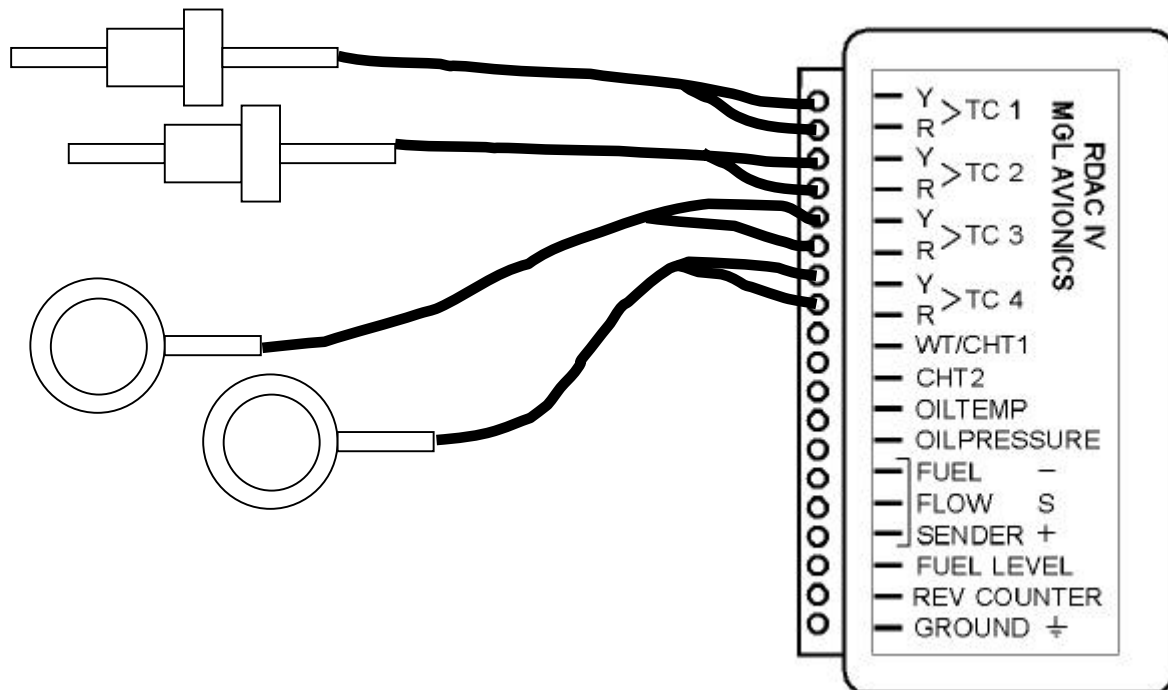

The thermocouple amplifier is a precision device providing full cold junction compensation and bow voltage correction. In addition the amplifier measures and corrects for its own errors. This results in very accurate measurements providing you install high quality probes. Here are some guidelines:

EGT Probes: Select probes that are made from 316 stainless steel and that use glass-fibre insulated conductors. Teflon insulated conductors as found in many cheaper probes introduce errors as the insulation melts moving the measuring point towards the mounting bolt which transfers a lot of heat to the exhaust material. This results in under reading probes. Stay away from probes that use simple plastic heat shrink sleeving – it does not last. Choose probes that use a generous amount of stainless steel spring as strain relief. The Bolt itself should be stainless as well or it will rust very quickly.

CHT probes: These are made from washers to fit spark-plug bases. Temperatures are considerably lower so most thermocouple cables will work without problems. The biggest area of concern should be the connection of the thermocouple cable to the washer. This often breaks after the spark plug has been changed a few times. Choose a probe that is suitably reinforced at this point for a long and trouble free life.

EGT and CHT probes supplied by MGL Avionics are of highest quality. We recommend that you consider using our probes if at all possible.

Warning: Four-stroke engines produce much hotter exhaust gases compared to two stroke engines. Do not use EGT probes made from lower grade stainless steel (for example 310), these probes will not withstand the high temperatures and can fail as the metal gets very soft at 800 °C. Many four strokes (such as the Rotax 912) will produce exhaust gases of up to 850 °C.

FUEL-FLOW SENDER INSTALLATION

The optional Fuel-Flow Sender is highly recommended for use with the *Stratomaster E2*. It provides instantaneous readouts of hourly fuel usage, as well as estimated endurance with remaining fuel. You can also verify the performance of your fuel pump during the pre-takeoff engine run up – a very valuable check !

It is possible to set up the *Stratomaster E2* to calculate remaining fuel by subtracting fuel actually used from a value entered when you filled your tank(s).

Note: Direction of fuel flow
Indicated by arrow on sender

RED wire – Fuel Flow Sender
Supply
BLUE wire – Fuel Flow Sender
signal
Braid – Fuel Flow Sender
Ground

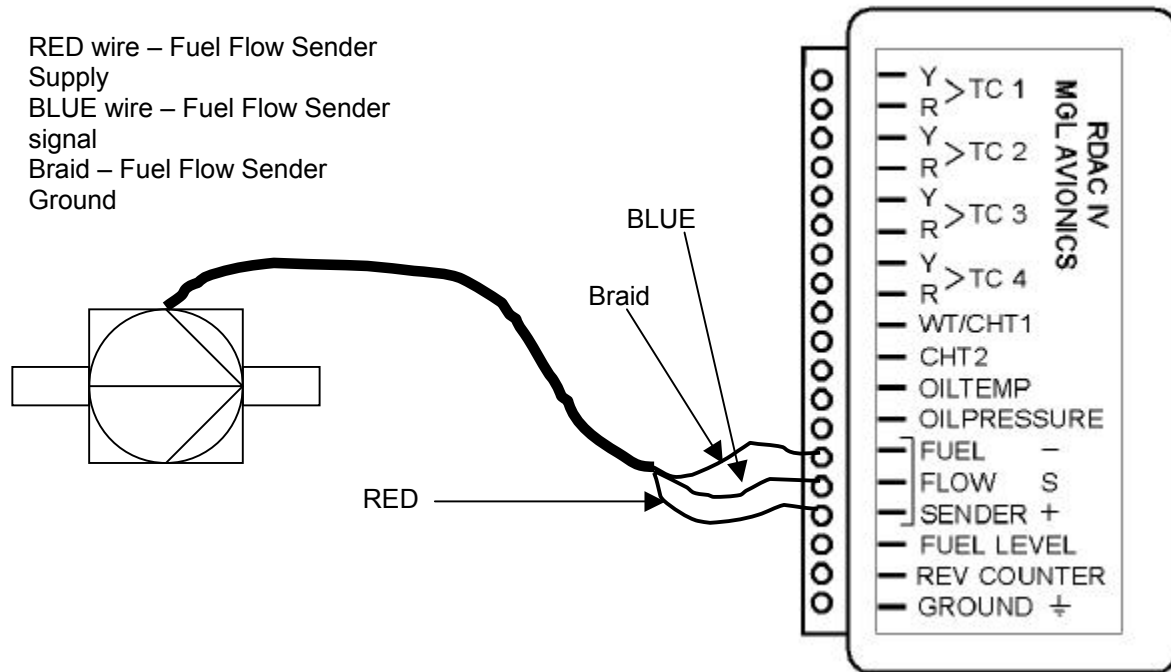

Warning: Incorrect wiring can damage both the RDAC unit as well as the flow sender.

Please note that the installation of the Fuel-Flow sender should be done in such a fashion that dirt or debris from the fuel tank cannot lodge inside the flow sender. These will not block you fuel flow but may lead to the impeller inside the sender jamming. It is usually sufficient to mount the Flow sender *after* the fuel filter but *before* the fuel pump. It is a good idea to provide a small reservoir such as a primer bulb between the flow sender and the fuel pump.

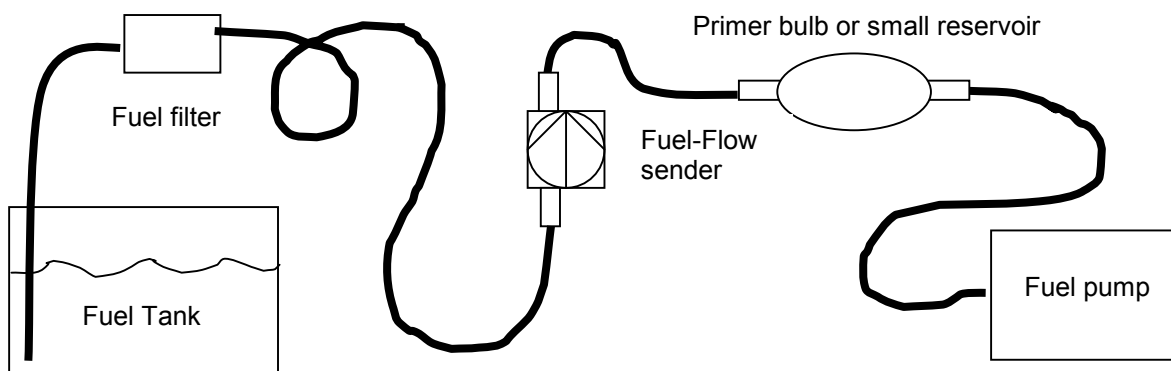

As indicated in the recommended fuel flow sender installation drawing, it can be of advantage to install the flow sender in such a fashion that the inlet points down and the outlet points up. This prevents vapour from forming a bubble inside the flow sender.

The flow sender is delivered with a small jet that can be installed in the flow sender inlet. Installation of this jet is recommended for engines with fuel flow rates lower than about 50 litres per hour. This would apply to most small two and four stroke engines.

The *Stratmaster E2* is shipped with the Fuel sender calibration set for the jet installed. In a good installation you can expect about +/- 3% maximum flow reading error with this factor. You can calibrate the flow sender yourself to a higher degree of accuracy if you so desire.

Recommended procedure to calibrate the fuel flow sender:

- Fill your tank exactly to a known level (for example 50 litres). Mark the level if necessary.
- Set your fuel level to 50 litres using the *Main Menu*. You may have to disable the fuel level sender first using the *Device Setup Menu* in order to enable this option.
- If you roughly know the number of pulses per litre (or preferred units of measure) that the fuel-flow sender generates, adjust the calibration factor for the closest displayed match (see *Fuel Flow Sender Calibration* on page 28)
- Fly your aircraft for a period that you know will use approximately 20 litres of fuel. The exact fuel burn is not important; just burn about 20 litres of your fuel. **DO NOT RELY ON YOUR FUEL LEVEL INDICATOR DURING THE FLIGHT AS IT HAS NOT YET BEEN CALIBRATED AND MAY BE OVER/UNDER READING.**
- After landing, the *Stratmaster E2* should give you a reading of how much fuel you have left – the reading should be about 30 litres left. The actual use is original level minus this remaining level (50 - 30 = 20 litres).
- Now place your aircraft in exactly the same position that you used when you first filled the tank and refill the tank to 50 litres using a measuring jug. You should find that you need 20 litres of fuel to refill to 50 litres.
- The difference between what you actually used and what the *Stratmaster E2* thought you used is the error we would like to calibrate out.
- Correct the calibration factor as follows:

$$\text{NewFactor} = \text{OriginalFactor} \times \text{ActualUse} / \text{ReportedUse}$$
- Repeat the above procedure to verify that your flow sender is now reading correctly.

Example:

Original fuel level:	50 litres
Actual fuel used (topup):	21.5 litres
Reported level after use:	29.7 litres
Reported fuel used:	(Original - Final) = 50.0 - 29.7 = 20.3 litres
Original calibration factor:	208
New factor:	$208 \times 21.5 / 20.3 = 220.3$ (select factor of 220)

Please note:

Before you calibrate the flow sender ensure there are no problems with your installation. We find the senders are very accurate if everything is installed and working properly. If your fuel burn indication is out by a large amount you have a problem that you should not attempt to fix by fiddling with the calibration factor !

Please ensure that no fuel vapour can be trapped inside the sender housing in the form of bubbles. Due to the low fuel flow rates the bubbles will prevent the tiny impeller from turning freely, You can verify the turning of the impeller. You should notice three dark spots that are just visible in the inside of the fuel flow sender. These are small magnets that are attached to the impeller. With fuel flowing you should see the magnets turning.

The best defence against vapour bubbles is to install the flow sender in such a way that the bubbles can escape. The easiest way is to point the outlet upwards and the inlet (with the jet) downwards.

Another possible problem is the fuel sender jet. When you install it, do not damage it. Use a drill bit of suitable diameter to push the jet all the way the opening of the jet must be just in front of the impeller.

Using other makes of Flow Senders

It is quite possible to use Flow Senders other than the RS device. In this case ensure that the Sender outputs a 5V TTL square wave or a similar signal. The *Stratomaster* interface electronics will adapt to a variety of different voltages and pulse shapes as it contains a Schmidt-trigger input stage. The calibration factor can be entered in a wide range making the unit particularly suited to other Flow senders.

The supply output terminal for the Sender provides a positive, regulated 5-volt output. This may be used to power the Flow Sender provided the Sender will not draw more than 40 mA of current. Should your sender require a higher voltage or more current, then you must supply the sender from a different power source. Exceeding the rating on the Stratomaster Flow sender supply terminal can affect the operation on the unit negatively or even damage it.

Settings for the calibration factor for other Flow senders can be estimated, using the following formulae:

Estimated calibration factor:

$1000 / (\text{Number of pulses per 4 second period for 1 litre/hour flow})$

Recommended Calibration Factors for RS Flow Sender Part No. 256-225

With jet installed = 208. Recommended with flow rates below 60 litres/hour maximum.

Without jet installed = 750. Recommended with flow rates above 60 litres/hour.

Please refer to the leaflet included with the Flow Sender for information on pressure drop vs. flow rate, wetted materials etc.

Disclaimer

It is your responsibility to ensure that the flow sender used is compatible with the fuels you intend using. We have found the RS sender to be very compatible with automotive fuels used in South Africa, many of which contain methanol. 100LL AVGAS also appears not to harm the sender in any way. We have exposed the RS sender continuously to our automotive fuels for two years without any noticeable ill effect on the sender.

Despite this however, MGL Avionics or its appointed agents cannot assume responsibility for any incident or damage, even loss of life by whatsoever cause connected with the fuel flow sender or the Stratomaster Flight Instrument. Usage of this or other senders is your own sole responsibility. If you do not agree with the above statement you must not use the fuel flow sender.

Note to Pilots

Always have a visual indication of the fuel level available, either by means of a sight glass, direct tank observation or a known, reliable secondary fuel level gauge. Fuel level indication by means of

calculated fuel burn is subject to errors both by entering incorrect starting fuel levels as well as mechanical problems causing the flow sender impeller to turn too slowly, resulting in under reading fuel burn and thus over reading remaining fuel.

As pilot in command of an aircraft it is your responsibility to ensure that you have sufficient fuel to reach your intended destination. Always ensure that you have a generous amount of reserve fuel and never use your reserve fuel except in an emergency if it is unavoidable.

CONNECTING A FUEL-LEVEL SENDER

Safety Hazard ! Please read this:

Be careful when installing fuel level senders into fuel tanks. Ensure that the fuel tank is completely empty when you proceed with the installation. Ensure that the fuel tank is well ventilated and does not contain any fuel vapours – these are highly explosive when mixed with air.

Ensure that at all times the ground connection (the connection of the fuel level sender mounting flange) is securely connected to the aircraft frame (in case of a metal frame) and to the negative terminal of the battery. In addition the negative terminal of the battery must at all times be connected to the Supply ground terminal of the RDAC.

Please note – this wiring is critical and must never break in flight. It would be possible to create electrical sparks in the fuel tank if your wiring is faulty or incorrect. The consequences of this can be imagined. This has nothing to do with the RDAC itself but is a general hazard for any automotive fuel level sender installation.

If you have no experience with electrical wiring, **PLEASE** delegate the task to a qualified automobile electrician or electronics technician.

If you need to remove the RDAC, first disconnect and secure the fuel level sender wire before disconnecting anything else.

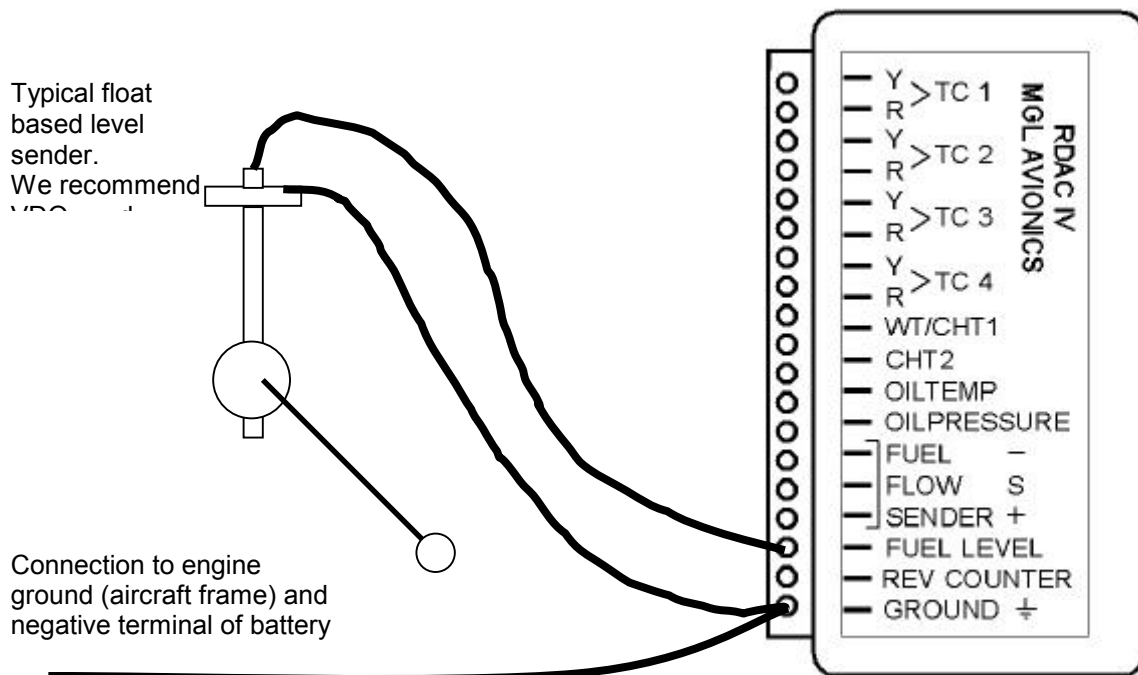

The *Stratmaster RDAC* permits the connection of a standard automotive fuel level sender. These senders can be obtained at automotive spares outlets at reasonable cost. When you choose a float level sender, ensure that you select a model that is sturdy and promises reliable and long lifetime. In particular, select a model that does not have any metal parts that can rust.

The *RDAC* can interface to a large variety of these fuel level senders. It does not matter if the sender resistance increases or decreases with the fuel level as long as it changes. The calibration procedure described on page 29 of this manual describes the procedure to follow.

In essence, the calibration procedure will measure the resistance of the fuel level sender at various fuel levels and then work out the readings in between those known settings.

Typical fuel level senders that can be used with the *Stratmaster RDAC* have resistance ranges in the region of 100 ohms to 500 ohms.

Tip:

It is possible to wire two fuel level senders in series if you have two fuel tanks. In this case the reading will be shown of the combined fuel level in both tanks.

CONNECTING THE REV COUNTER

The rev counter input can be connected to a variety of different sources such as the low voltage side of a ignition coil (at the points contact breaker) or to rev counter outputs of fuel injection computers.

Note The *RDAC* package contains a 220 ohm resistor. Normally it is not required but we have found a few Rotax engines that create a very noisy signal and it may help in this case. The problem manifests itself by several rev band regions giving unstable rev readings. Should you be unlucky enough to have one of these systems, please connect the resistor between the rev counter input and the ground input in parallel to your connection to the grey rev counter wire from the engine.

Typical connection in case of a Rotax two stroke engine with Ducati dual ignition:

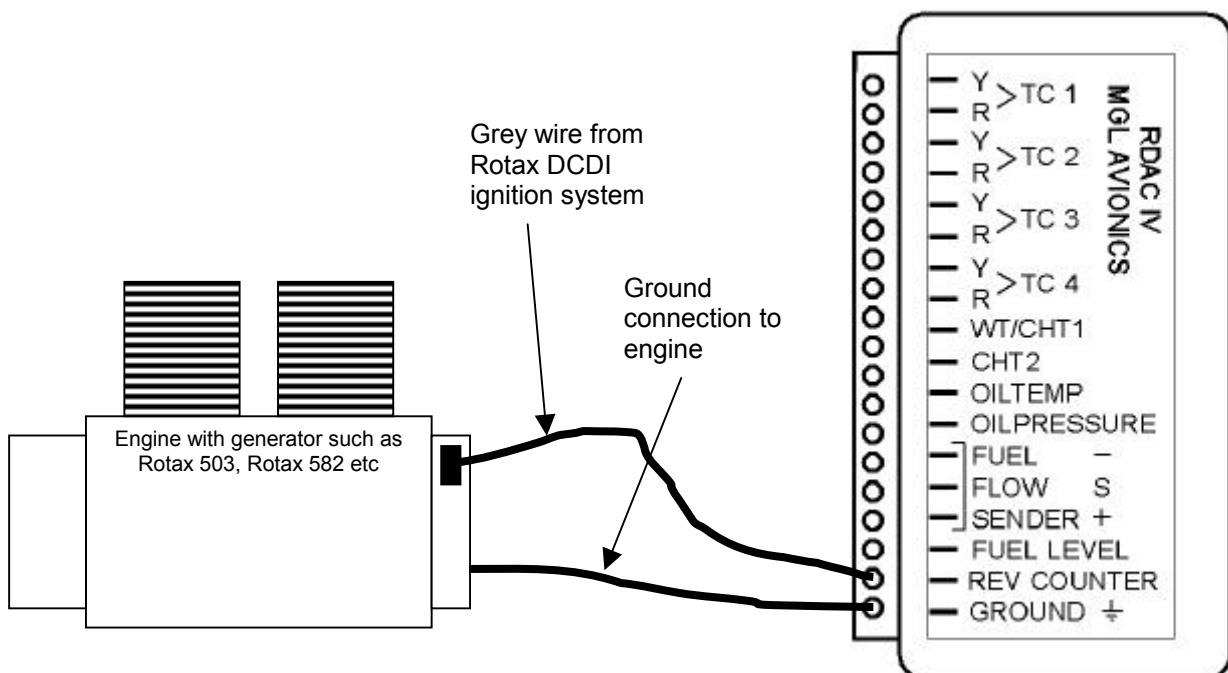

TYPICAL INSTALLATION EXAMPLES

Rotax 503

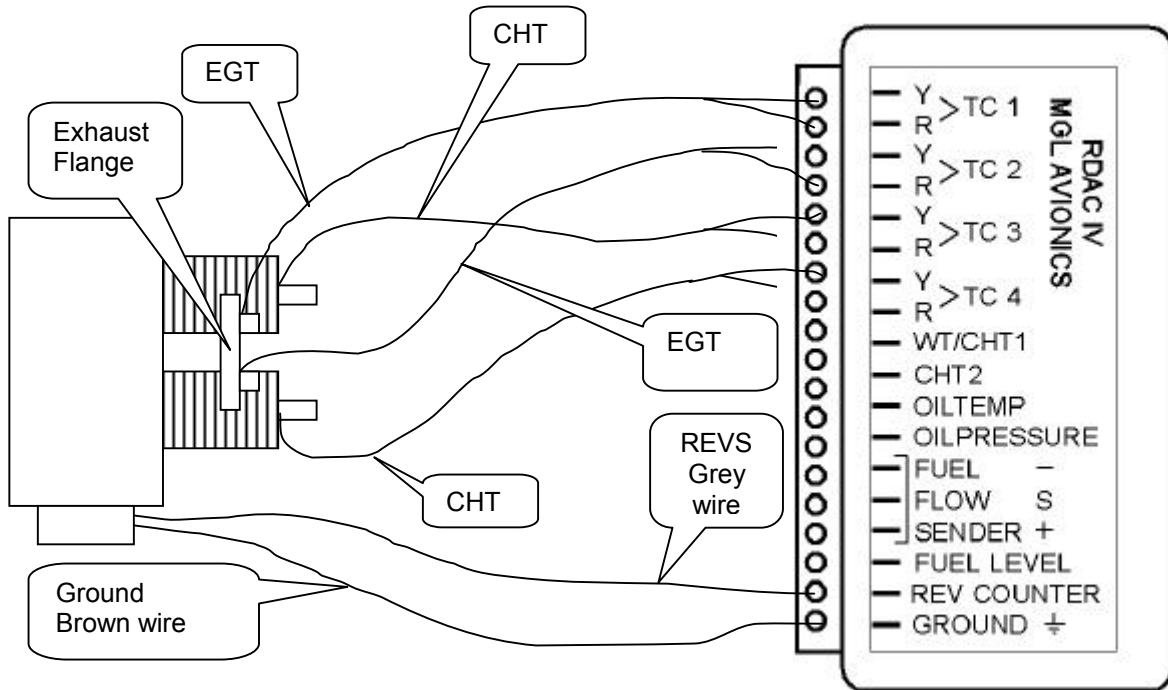

Rotax 582

Note: CHT is optional on the 582.

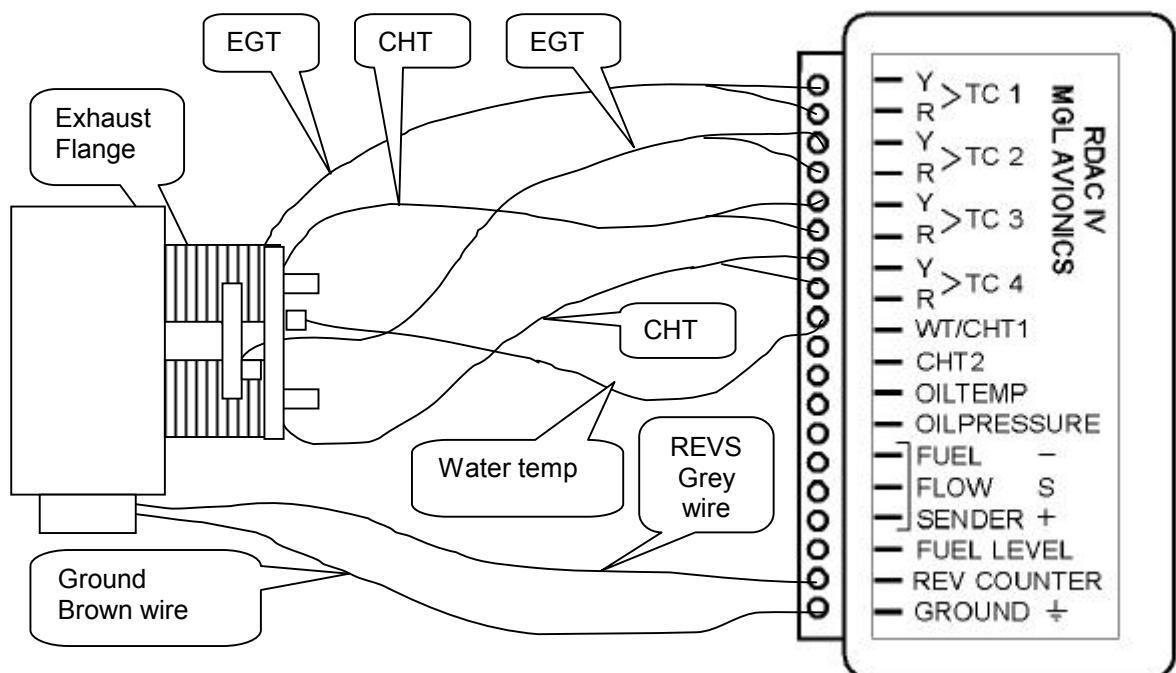

Rotax 912

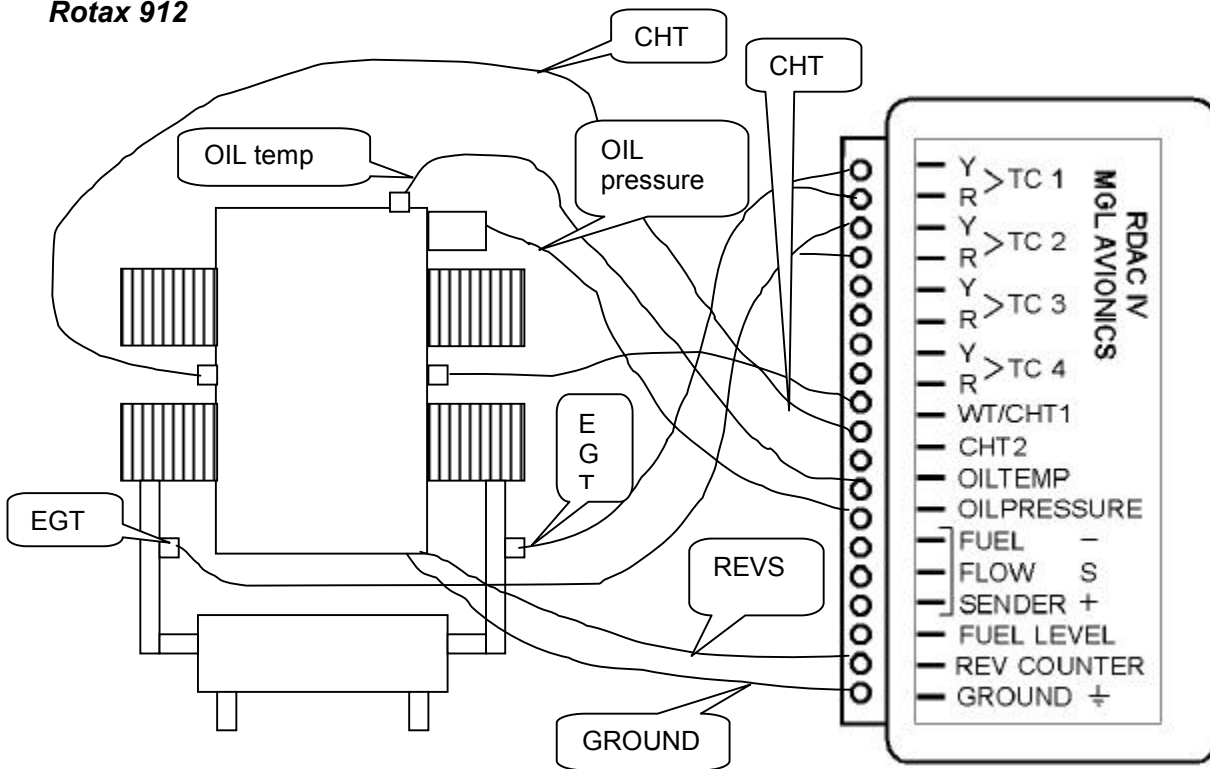

USING THE SYSTEM

UNDERSTANDING THE DISPLAY

A typical configuration of the *Stratmaster E2* display is shown in the figure below. This is the display shown during normal use whether the engine is running or not. Display layout may change depending on your configuration setup but all readings are continuously displayed with display updates occurring every half second.

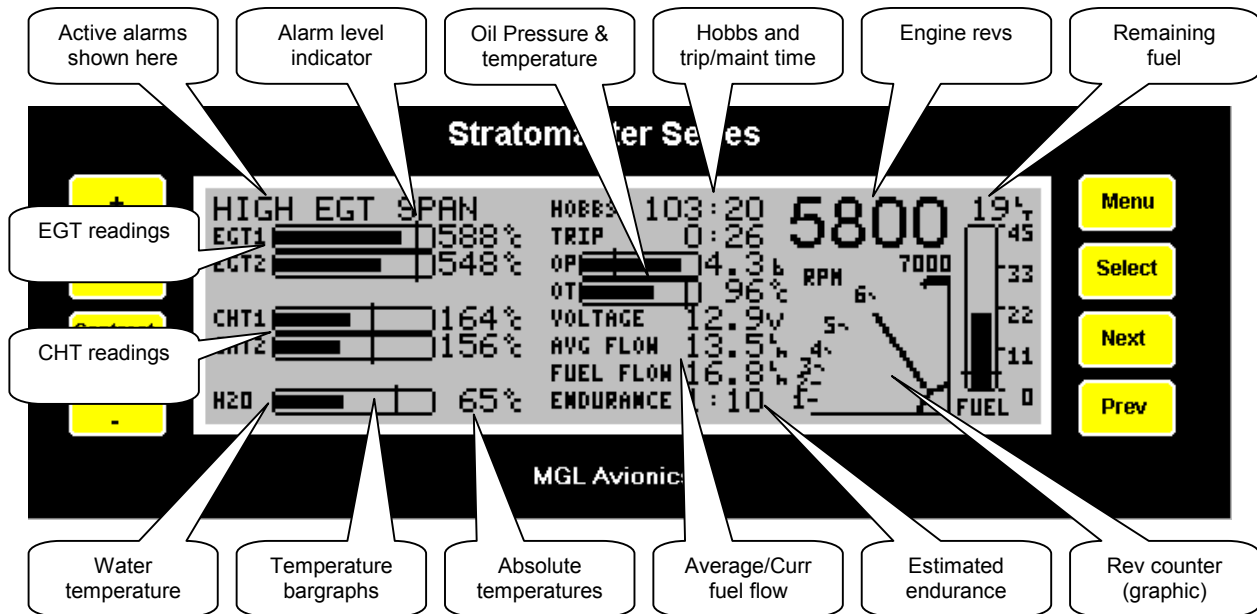

EGT Readings

EGT (Exhaust Gas Temperature) bargraphs are always shown grouped together in the top left corner of the display. Having all EGT readings grouped together allows relative differences between readings to be instantly noted. Such differences would normally indicate a developing problem in one cylinder. Each graph is labelled on the left with the absolute temperature in the units of choice (Centigrade or Fahrenheit) shown on the right to one degree resolution.

Full scale on the graph is specified in the Range setup menu with the low range being half the full-scale reading.

Also shown on the graph is a line indicating the alarm level that has been set. In the example shown, EGT2 has exceeded the alarm level and this bargraph will thus be blinking. An audible and/or external alarm indicator will also be activated. The alarm may be acknowledged by pressing any key which then silences the external alarm but the display continues blinking until the alarm condition clears. The message on the top left displays a scrolling list of all current alarm conditions - in this case, a high EGT reading.

What EGT Can Tell You

EGT readings give a direct indication as to the efficiency of your fuel burn. Even small changes to any of fuel, air, compression, ignition or timing will all produce noticeable changes in EGT. This can be used to identify a problem before it becomes an expensive disaster as well as allow you to adjust your fuel mixture and cruise at maximum efficiency. The following table indicates some of the problems that EGT readings may detect:

Condition	Typical Problem
EGT rises by more than 50 °C (100 °F)	Pre-ignition
EGT rises in one cylinder by 25-50 °C (50-100 °F)	Fouled spark plug Faulty ignition Intake manifold leak Reduced fuel supply (Eg: partially plugged injector)
EGT increase in all cylinders	Magneto failure Overly retarded ignition timing
EGT decrease in all cylinders	Air filter restriction Carburettor ice Overly advanced ignition timing
EGT decrease in one cylinder	Faulty intake valve Low compression

Lean Mode

EGT information is also very useful for fuel mixture control. As the fuel mixture is leaned, so the exhaust gasses get hotter. This rise in temperature is a sign of increased combustion efficiency as the optimum mixture setting is approached. If the leaning progresses past a certain point however, the temperature will begin to drop. This temperature drop is the result of reduced energy output from the diminished fuel flow. The best operating mixture for aircraft engines is in the vicinity of this peak EGT reading. The *Stratmaster E2* has a special *Leaning Mode*, which easily identifies the peak EGT condition allowing you to adjust your fuel mixture for best performance.

Fuel mixture should be adjusted once you have decided on a suitable cruise power setting (typically 70%). Press and hold **+** at the main display for 1 second to enable *Leaning Mode*. The display shows "**LEAN MODE...**" and the *E2* begins a careful watch on each of the EGT readings. As the fuel mixture is slowly leaned past the point at which the temperature begins to drop (by more than 5 °C), the display will change to show the cylinder which first reached its peak and will show the EGT reading relative to this peak reading. At this point, the mixture should be enriched once more until the reading is about 25 °C (50 °F) below its peak. During *Lean Mode* the *E2* displays temperatures below their peak as the difference between the actual and peak reading (Eg: -25 °C). All other EGT readings will show the difference from their reading at the time the first cylinder reached its peak. This may or may not be its own specific peak value.

Lean mode may be cancelled by pressing the - key. Pressing the **+** key after leaning has been completed will enter the *Cruise mode* allowing the current settings to be monitored.

Cruise Mode

Once in the cruise, pressing the **+** key will immediately enable *Cruise Mode*. The display shows "**CRUISE MODE...**" and all EGT and CHT readings are immediately sampled as reference temperatures for the cruise. The display then shows EGT and CHT values as a relative difference from this reference temperature. The *E2* continuously monitors each EGT and CHT reading and triggers an alarm if any reading deviates by more than the specified *Cruise* amount above or below the reference. *Cruise* deviations are set under the *Range Menu* (see page 30).

Pressing the **+** key will always immediately reset the reference temperatures to the current temperatures. *Cruise mode* may be cancelled by pressing the - key and may be resumed (with the original reference temperatures) by pressing - again.

CHT Readings

Below the EGT readings are CHT (Cylinder Head Temperature) readings. Like the EGT graphs, relative and absolute temperatures are both easily visible at a glance.

Water Temperature

If setup, water (coolant) temperature may be displayed on a bargraph like the EGT/CHT graphs. Full-scale reading and alarm levels are adjustable under setup menu options with lower limit being approximately half the full-scale reading.

Oil Temperature / Pressure graphs

In the centre of the screen, assuming they have been setup for display, are oil pressure (OP) and oil temperature (OT) bargraphs. Like EGT and CHT graphs, they show absolute readings in units of choice as well as the bargraph and alarm level indicator for a quick visual indication of status.

Fuel Level Display

On the far right is a bargraph showing remaining fuel relative to tank capacity and as an absolute value in units of choice at the top of the graph. Fuel level is only displayed if a fuel level or fuel flow sender has been installed.

Rev Counter

The rev counter is shown as an analogue style gauge for quick visual reference as well as a prominently displayed RPM value. The rev counter gauge has a logarithmic scale to provide better resolution at high revs. The engine high rev alarm may be configured to only activate after the revs have been exceeded for longer than a specified time (Eg. 6 minutes). If the absolute maximum RPM value is exceeded, the alarm is immediately activated.

Hobbs Meter

The *Hobbs Meter* displays a total engine running time in hours and minutes (selectable to display decimals of an hour). It automatically accumulates time whenever the engine revs exceed the specified engine Hobbs revs. This value allows engine idle time to be ignored for Hobbs reading purposes. Set the value to zero to record time whenever the engine runs. The Hobbs revs and Hobbs meter reading may be preset under the *User Preferences* Menu (page 31).

An associated *Trip Time* display (beneath the Hobbs meter) can be configured to automatically reset on engine startup and thus display the total engine running time for the current flight or it can be manually reset in which case it records total running time since last reset. This can be useful for flight schools which charge students according to engine running time rather than lesson time. The timer always starts running together with the Hobbs meter.

Maintenance Timer

An engine maintenance timer may be preset at any time and the *E2* counts this time down to zero whenever the engine is running. An alarm is generated once this reading reaches zero in order to indicate that scheduled maintenance on the engine is due (Eg: spark plug replacement). The maintenance timer alternates with the previous flight's run time once the engine has stopped but is otherwise hidden while the engine is running (It may still be viewed/edited via the *User Preferences* Menu).

Ambient Temperature

With external ambient temperature probe connected, the ambient air temperature can be displayed in units of choice. This display alternates with input voltage reading if no space is available due to display of oil pressure and oil temperature graphs. If no external ambient temperature probe is fitted, the internal temperature of the RDAC unit will be used instead but this reading is likely to be higher than ambient due to engine proximity and RDAC self heating.

Input Voltage

This display indicates the voltage measured on the input to the *Stratomaster E2*. It may alternate with display of ambient temperature if installed and no other space is available due to display of oil pressure and oil temperature graphs.

Fuel Flow and Fuel Totalizer

If an optional fuel-flow sender is installed, both average and instantaneous fuel flow rate (in units of choice per hour) may be displayed. In addition, a *fuel totalizer* meter becomes available. This allows a continuous tally to be kept of all fuel passing through the fuel-flow sender. The average fuel flow rate is calculated over this total amount. The *fuel totalizer* (and average flow rate) may be reset at any time via an option in the *Main Menu*.

With a fuel-flow sender installed, fuel level may be measured by subtracting actual fuel used from an initial known amount in order to predict remaining fuel in the tank. This method of fuel level calculation may be preferred if no fuel level sender is available or if motion of fuel in the tank causes erratic level indications. The initial amount may be manually set under the *Main Menu* and can be initialised to the current fuel level as determined by a fuel level sender (press and hold + and - keys simultaneously at the *Set Level* option).

Estimated Endurance

If the fuel-flow sender option is installed, knowing remaining fuel level allows an estimated endurance on remaining fuel at current burn rate to be calculated and displayed. This gives a continuous estimate of endurance (in hours and minutes) at current flow rate allowing critical fuel management decisions to be made timeously as well as allowing a suitable cruise speed to be found to maximise fuel efficiency.

THE MENU SYSTEM

All setup or user options made on the *Stratomaster E2* are performed via system *menus*. To bring up the main menu, press the **MENU** key. Once the menu system is active, it can be cancelled by once more pressing **MENU**, which then returns to the previous menu or the main display.

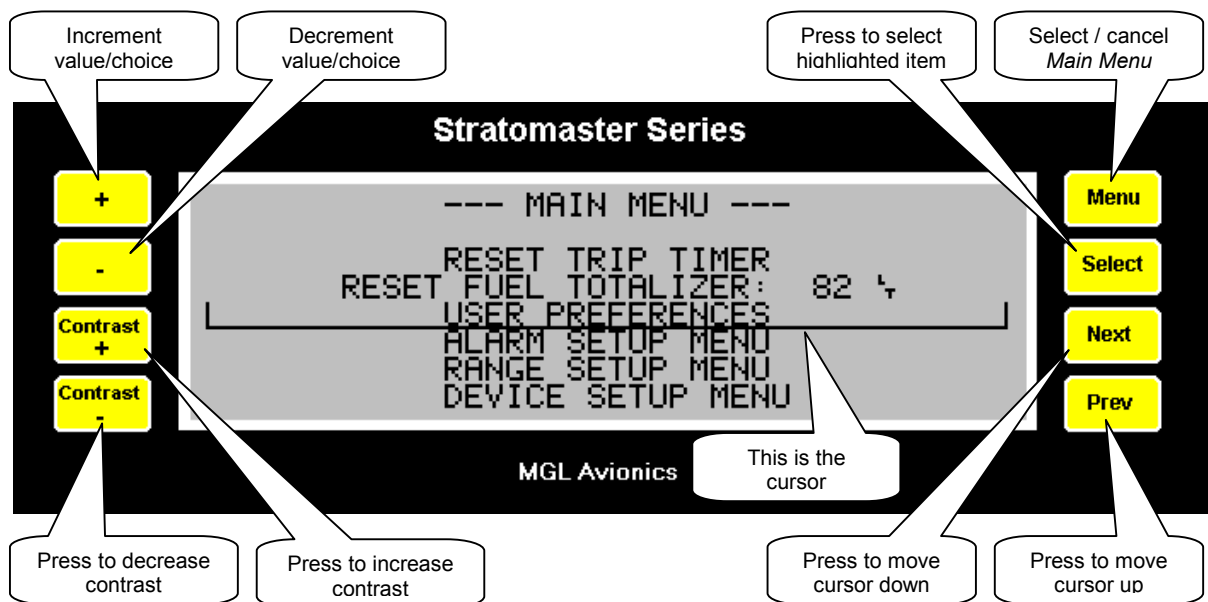

A menu consists of a list of *menu items* with the currently selected item being highlighted by the so-called *cursor*. The *cursor* may be moved up and down through the list using the **NEXT** and **PREV**

keys. In some cases there may be more items than can be displayed on one screen. In this case, selecting **NEXT** (at the bottom) or **PREV** will scroll the entire display to reveal the hidden items. To select or activate the highlighted entry, press the **SELECT** key.

Some items may allow a number of different options to be selected or a value to be specified. In this case, select between the available options or adjust the displayed value up or down using the **+** and **-** keys. These keys have an auto-repeat facility that allows you to simply hold the key down while it automatically increases or decreases the displayed value. When the correct value is displayed, release the key and either close the menu (by pressing **MENU**) or move on to the next item (using **NEXT** or **PREV**).

All changes made to settings are permanently stored and need not be re-set every time the unit is switched on.

Resetting the Trip-Timer

If the *Trip-Timer* has been set to *Manual Mode* an option appears in the *Main Menu* to allow it to be reset. Selecting this option will then display a warning that the *Trip-Timer* is about to be reset. Press the **+** key to confirm this operation or any other key to cancel.

Resetting the Fuel Totalizer

If a fuel-flow sender is installed, a *Fuel Totalizer* becomes available which continuously totals all fuel used. The total (and associated average fuel flow) may be manually reset by selecting this option. A warning message is then displayed. Press the **+** key to confirm the operation or any other key to cancel.

User Preferences

The *User Preferences Menu* allows the selection of a number of options that relate to the way you want your *Stratmaster E2* to work. (See page 31)

ALARM CONDITIONS

Each of the various readings has an associated alarm level at which point an alarm will be activated to highlight the condition. The top left line of the display will continuously scroll through all alarm conditions indicating which have been triggered.

When an alarm is triggered, the relevant display is set to blink once a second and an uncommitted relay contact is also pulsed at the same rate. This may be connected to, for example, an alarm lamp or buzzer in order to draw attention to the alarm condition. In addition, an audible alarm signal is generated by the *E2* which may be fed directly into your intercom system or to a panel mount speaker.

An alarm condition must be acknowledged by pressing any key which then disables the audio tone and the relay contacts but the offending display remains blinking until the condition is rectified. An alarm condition is only considered cleared once its level drops below the alarm trigger level by a small amount (Eg: 5 degrees C)

SYSTEM CONFIGURATION

The *Stratomaster E2* has been designed to work with a variety of engines, temperature, pressure, fuel level, and fuel flow senders. Specific configuration details are split into four separate menus:

- The *Device Setup Menu* is used to specify what should be measured and how (probe types)
- The *Range Setup Menu* specifies the maximum readings that will be displayed. This sets the limits of the graphs that are displayed.
- The *Alarm Setup Menu* is used to set the operating limits of each measurement. When these operating limits are exceeded, an alarm condition is triggered and the offending measurement is flashed to attract your attention.
- The *User Preferences Menu* allows setting of personal preferences such as units of measure.

DEVICE SETUP - WHAT SHALL WE MEASURE TODAY?

All measurement probes connect to the system via the *RDAC* unit which has four thermocouple inputs (TC1 to TC4), three NTC inputs (labelled WT/CHT1, CHT2 and OILTEMP), an oil pressure input (OILPRESSURE) and Fuel Flow, Fuel Level and Rev Counter inputs. Select the *Device Setup Menu* from the *Main Menu* to allow to specify which of these inputs are to be used with what probes.



Engine Quick Select Menu

A number of standard configurations are stored in the *E2*. By recalling the relevant setup, all the required details will automatically be set, including probe configurations, bargraph display ranges and alarm levels. This is probably always a good way to start as most of the details will be correct, requiring perhaps only one or two modifications to suit your particular needs.

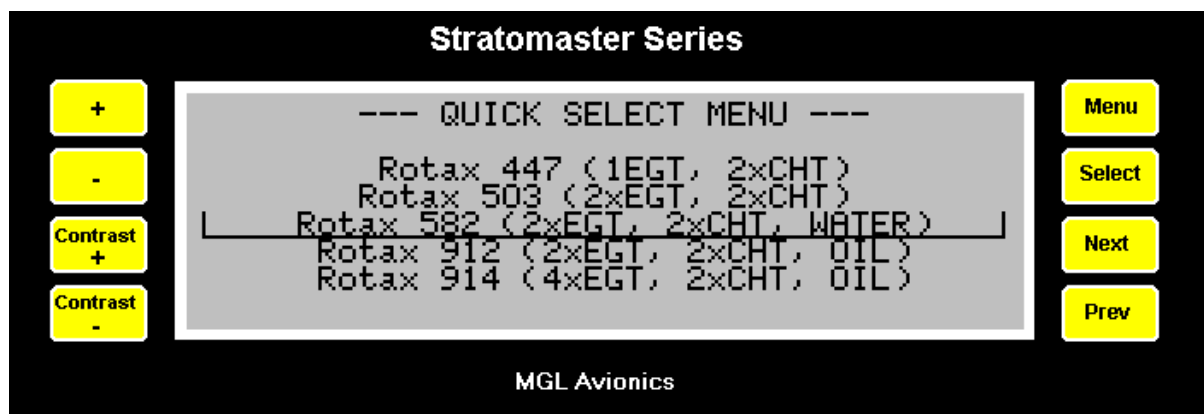

The following standard configurations are available under the *Quick Select Menu*:

- Rotax 447
 - 1 x EGT (K-type) thermocouple on inputs TC1
 - 2 x CHT (K-type) thermocouples on inputs TC3, TC4
 - No water / oil temperature
 - No oil pressure
 - EGT Max Bargraph: 650 °C (1200 °F)
 - CHT Max Bargraph: 300 °C (570 °F)
 - EGT High Alarm: 620 °C (1150 °F)
 - EGT Span Alarm: 25 °C (45 °F)
 - CHT High Alarm: 260 °C (500 °F)
 - Max Revs: 7000
 - High Rev Alarm: 6800 RPM (no delay)
 - Rev Counter Calibration: 60 pulses per 10 revs

- Rotax 503
 - 2 x EGT (K-type) thermocouples on inputs TC1, TC2
 - 2 x CHT (K-Type) thermocouples on inputs TC3, TC4
 - No water / oil temperature
 - No oil pressure
 - EGT Max Bargraph: 650 °C (1200 °F)
 - CHT Max Bargraph: 300 °C (570 °F)
 - EGT High Alarm: 620 °C (1150 °F)
 - EGT Span Alarm: 25 °C (45 °F)
 - CHT High Alarm: 250 °C (480 °F)
 - Max Revs: 7000
 - High Rev Alarm: 6800 RPM (no delay)
 - Rev Counter Calibration: 60 pulses per 10 revs

- Rotax 582
 - 2 x EGT (K-type) thermocouples on inputs TC1, TC2
 - 2 x CHT (K-Type) thermocouples on inputs TC3, TC4
 - 1 x MGL NTC Water Temp sender on input WT
 - No oil temperature/pressure
 - EGT Max Bargraph: 650 °C (1200 °F)
 - CHT Max Bargraph: 150 °C (350 °F)
 - EGT High Alarm: 620 °C (1150 °F)
 - EGT Span Alarm: 25 °C (45 °F)
 - CHT High Alarm: 130 °C (300 °F)
 - Water Temp Max: 90 °C (190 °F)
 - Water Temp Alarm: 80 °C (180 °F)
 - Max Revs: 7000
 - High Rev Alarm: 6800 RPM (no delay)
 - Rev Counter Calibration: 60 pulses per 10 revs

- Rotax 912
 - 2 x EGT (K-type) thermocouples on inputs TC1, TC2
 - 2 x CHT (K-Type) thermocouples on inputs TC3, TC4
 - 1 x ROTAX Oil Temp sender on input OILT
 - 1 x ROTAX Oil Pressure sender (200 ohms) on input OILP
 - EGT Max Bargraph: 900 °C (1650 °F)

CHT Max Bargraph: 180 °C (1560 °F)
 EGT High Alarm: 850 °C (°F)
 EGT Span Alarm: 25 °C (45 °F)
 CHT High Alarm: 150 °C (300 °F)
 Water Temp Max: 90 °C (190 °F)
 Water Temp Alarm: 80 °C (180 °F)
 Max Oil Temp Bargraph: 160 °C (320 °F)
 Oil Temp High Alarm: 140 °C (280 °F)
 Max Oil Pressure Bargraph: 5 bar (70 PSI)
 Oil Pressure Low Alarm: 2 bar (30 PSI)
 Max Revs: 6000
 High Rev Alarm: 5800 RPM (after 2 minutes)
 Rev Counter Calibration: 10 pulses per 10 revs

- Rotax 914
 - 4 x EGT (K-type) thermocouples on inputs TC1, TC2, TC3, TC4
 - 2 x CHT (ROTAX NTC) on inputs CHT1, CHT2
 - 1 x ROTAX Oil Temp sender on input OILT
 - 1 x ROTAX Oil Pressure sender (200 ohms) on input OILP
 - EGT Max Bargraph: 900 °C (1650 °F)
 - CHT Max Bargraph: 180 °C (1560 °F)
 - EGT High Alarm: 850 °C (°F)
 - EGT Span Alarm: 25 °C (45 °F)
 - CHT High Alarm: 150 °C (300 °F)
 - Water Temp Max: 90 °C (190 °F)
 - Water Temp Alarm: 80 °C (180 °F)
 - Max Oil Temp Bargraph: 160 °C (320 °F)
 - Oil Temp High Alarm: 140 °C (280 °F)
 - Max Oil Pressure Bargraph: 5 bar (70 PSI)
 - Oil Pressure Low Alarm: 2 bar (30 PSI)
 - Max Revs: 7000
 - High Rev Alarm: 6700 RPM (after 6 minutes)
 - Rev Counter Calibration: 10 pulses per 10 revs

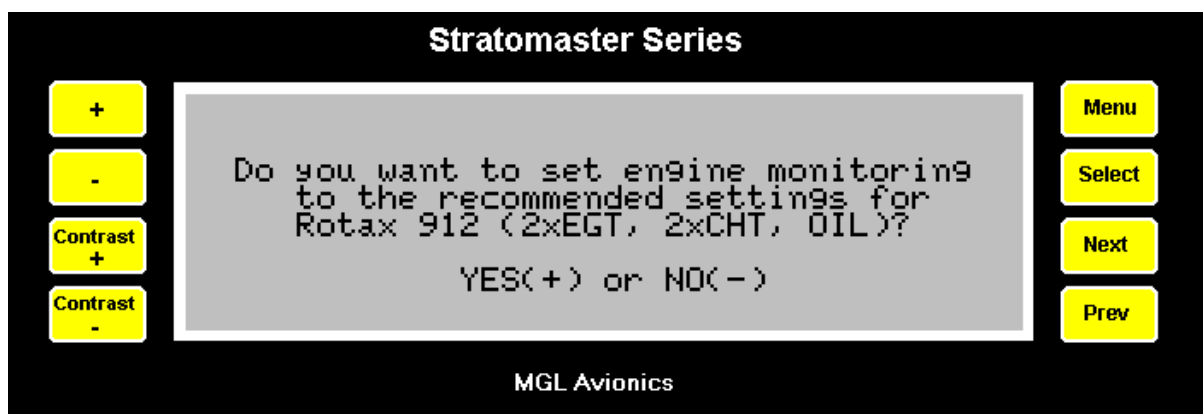

After selecting the required engine, we must confirm the operation by pressing +. Pressing any other key cancels the operation.

Sender Setup Menu

Once the basic engine type has been specified you can use the *Sender Setup Menu* to adjust any individual sender requirements to suit actual sender requirements.

Use the **NEXT** and **PREV** keys to select the item to change and **+** and **-** to change the item.

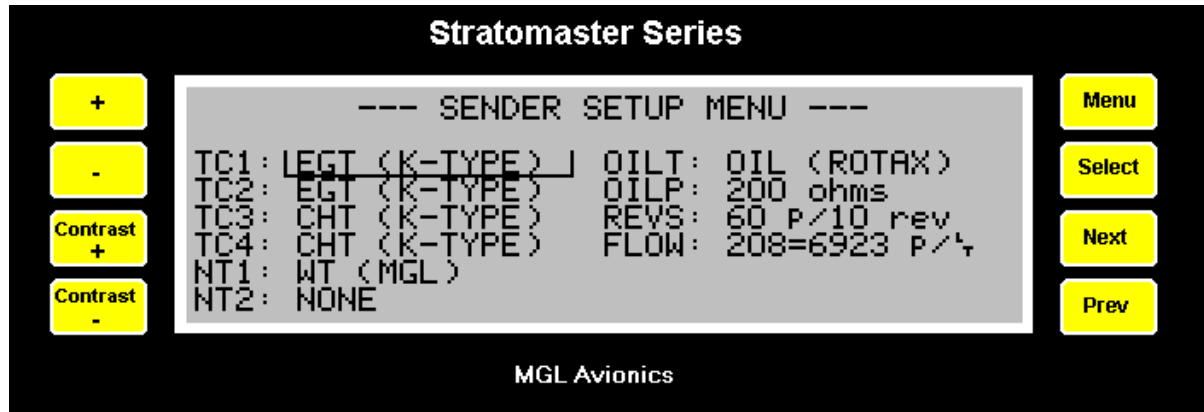

Thermocouple Inputs (TC1 to TC4)

Thermocouples may be used to measure both EGT and CHT readings. There are two types of thermocouple probes that may be used on the *RDAC* which have different electrical characteristics and the probe type must therefore be specified as either (**J-TYPE**) or (**K-TYPE**) devices. Most thermocouples are K-type devices but some older CHT probes (particularly in the US) may be J-type.

Select the type of probe connected to the input from the following list: (press **+** or **-**)

- **NONE** Input is not used
- **EGT (J-TYPE)** J-Type thermocouple used for EGT reading
- **EGT (K-TYPE)** K-Type thermocouple used for EGT reading
- **CHT (J-TYPE)** J-Type thermocouple used for CHT reading
- **CHT (K-TYPE)** K-Type thermocouple used for CHT reading

NT1, NT2 and OILT Inputs

These *Negative Temperature Coefficient* (NTC) inputs can be used to measure CHT, WATER, AUX or OIL temperature.

- **NONE** Input is not used
- **CHT** Input is used to measure CHT reading
- **WT** Input is used to measure Water temperature
- **AUX** Input is used to measure *Auxiliary* temperature
- **OIL** Input is used to measure Oil temperature

The *Stratomaster E2* caters for three different types of probe on each of the above inputs:

- **MGL** CHT / Water temperature probe as supplied by MGL Avionics
- **ROTAX** CHT / Water temperature probe as supplied by Rotax
- **SILICON** Precision CHT / Water temperature probe made by MGL Avionics based on the LM335.

Select the required combination of the above options using the **+** or **-** keys.

OILP Input

This input caters for a resistive oil pressure sender with ranges from 50 to 1000 ohms. The standard Rotax oil pressure sender is 200 ohms. Select the appropriate resistance (or NONE if no oil pressure will be measured) using the + or - keys.

REVS Calibration

The *Stratmaster E2* includes a very flexible rev counter that can be adapted to a very wide variety of engines. This is done in the *Sender Setup Menu*. Here you enter the number of pulses the rev counter pickup (whatever it may be) will generate for every ten revolutions. The instrument will use this information to work out revs from the time it takes to complete ten revolutions of the engine. This way, high resolution of the rev counter is guaranteed even if only one pulse is generated for a single revolution as would be the case for the 912 engine.

Pickups vary from those provided by the engine manufacturers in the form of magneto coil tapings (Rotax / Ducati) to anything from a few loops of wire coiled tightly around one of the ignition wires to pickups from generator A/C outputs or the W output of a car type alternator. In fact, anything that is able to provide at least a 3-4 volt, reasonably stable signal at the rev counter input of the *RDAC* system. Signals with a voltage as high as 100 volts can be used as well (as is the case with Ducati systems if no ballast resistor is fitted).

On unusual engines it is often a matter of experimenting with various pickup methods to find a satisfactory solution. Once a stable reading can be obtained, set the calibration of the rev counter so that correct revs are indicated.

A value of 60 is used for most two-stroke Rotax engines based on the Ducati DCDI system (6 pulses per rev). Rotax 912/914 engines produce 1 pulse per rev so the correct setting would be 10.

Select the value according to your engine's tach generator output for all other engines. For engines without a tach generator such as a VW, we suggest that you try a pickup using a wire looped tightly about 20 times around one of the spark plug leads. (See installation manual for further details on this method). A spark is generated every second revolution per cylinder on a four stroke engine so you should enter a value of 5 in this case. You can also try pickups directly from the switched end of the ignition coil (points). This may give you a better signal. In this case the factor to be entered will depend on the number of cylinders. You should find two cylinders firing for every revolution in a typical four-cylinder, four-stroke engine so this would give you a factor of 20.

Fuel Flow Sender Calibration

The fuel-flow sender consists of a small impeller that rotates as fuel flows past it. This then creates a series of pulses at a rate determined by the rate of fuel flow. The *Stratmaster E2* counts the number of pulses received within a short time and then uses the calibration constant for the sender to determine the actual fuel-flow rate per hour.

The calibration constant can be adjusted up and down using the + or - keys and displays the current value together with the corresponding number of pulses per litre (or your preferred unit of measure). The default fuel-flow calibration is set for use with the recommended RS device. This should give an accuracy of $\pm 3\%$. Should you use a different fuel-flow sender, the sender may be calibrated using the procedure described on page 12.

Ambient Temperature Sender

If an ambient temperature sender (supplied) has been installed, select "**HAS AMBIENT TEMP**" in the *Device Setup Menu*. If not, select "**NO AMBIENT TEMP**". In this case, ambient temperature will be taken from the internal temperature sensor on the *RDAC*. This is a compromise since the *RDAC* internal temperature could be substantially higher than actual ambient temperature so use of the supplied ambient temperature sensor is highly recommended.

Fuel Flow Sender

If a fuel-flow sender is installed, select "HAS FUEL FLOW SENDER" in the *Device Setup Menu*. If not, select "NO FUEL FLOW SENDER" to disable this option.

Fuel Level Sender

If a fuel-level sender is installed, select "HAS FUEL LEVEL SENDER" in the *Device Setup Menu*. If not, select "NO FUEL LEVEL SENDER" to disable this option. If this option is disabled but a fuel-flow sender is installed, fuel level will be calculated by subtracting all fuel flow measurements from an initial fuel quantity setup under the *Main Menu*. This may be a preferred method of deriving remaining fuel, even if a fuel level sender is installed since it has the advantage of being totally immune to any movement of fuel in the tanks which may cause incorrect readings from a float style level sender.

With both a *Fuel-Flow* and *Fuel-Level* sender installed, an option becomes available in the *User Menu* to determine whether fuel levels should be measured directly or calculated from actual fuel flow. It may be desirable to calculate fuel level if you find the fuel level sender does not show stable readings as fuel sloshes about in the tank. The *Stratomaster E2* averages out readings in order to eliminate such inaccuracies but if too severe, calculated levels should be used.

Fuel Level Sender Calibration

If no fuel level sender is available but a fuel-flow sender is installed, fuel level may be calculated from flow and in this case, this option simply allows the tank capacity to be specified.

If a fuel-level sender has been installed, selecting this option allows the fuel level sender readings to be compensated for tank shape. Calibration involves filling the tank with known quantities of fuel and noting the readings obtained from the fuel level sender. Accurate measurement of remaining fuel is then obtained by reading the fuel level sender and interpolating an actual fuel level from the calibration table.

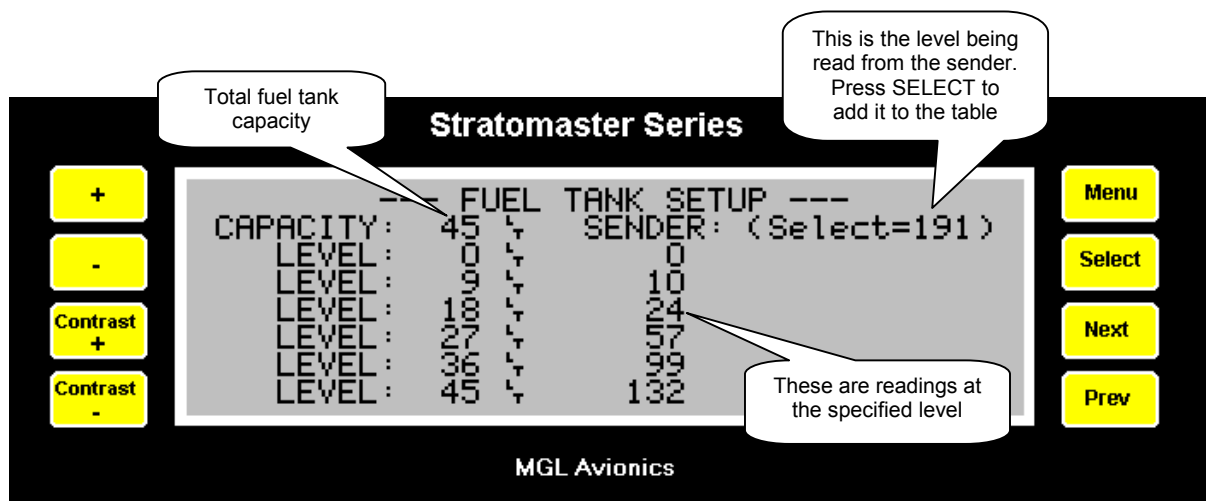

Begin the calibration procedure by emptying the tank and specifying its total capacity (in units of choice). This will then divide the tank into 5 equal levels, with these levels being displayed. The calibration procedure involves filling the tank to the five different levels specified and noting the reading obtained from the level sender. Care should be taken that the exact amount of fuel specified is added for each reading. Once the fuel level reading has stabilised, pressing **SELECT** at the appropriate level will enter the current sender reading into that location. The value may also be manually corrected up and down using the + or - keys.

RANGE SETUP - MAXIMUM LIMITS

The *Range Setup Menu* specifies the maximum readings that will be displayed on the various graphs. Since most temperature readings are normally within a small band, to increase resolution, the bargraphs only start showing temperatures from approximately half of the maximum reading. Also included under *Range Setup* are the cruise ranges (allowable change above and below cruise level) for *Revs*, *EGT* and *CHT* readings.

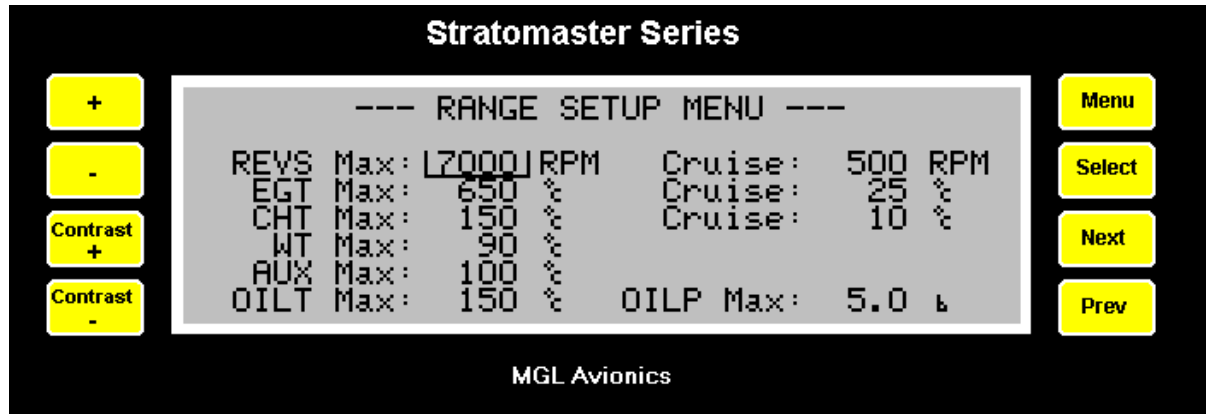

ALARM SETUP - ABNORMAL READINGS

The *Stratomaster E2* has a comprehensive list of alarm limits, which are continuously monitored. If any of these levels is exceeded, the alarm is triggered with the appropriate message appearing on the display and a flashing indicator to attract your attention.



The engine *Revs Delay* option allows a delay to be set with the alarm only triggering after the over-rev condition has continued for this period. This allows use with engines such as the Rotax 914 with turbo-charger where over-revs are only considered a problem once they have been continued for six minutes or more. If the over-rev condition, exceeds the *Max Revs* value specified under the *Range Setup Menu*, the delay is ignored and the alarm triggers instantly.

EGT Span and *CHT Span* values are the maximum differences permitted between readings on different cylinders. Such differences would indicate a potential problem.

OP (oil pressure), *Fuel level* and *Endurance* levels are considered *minimum* levels and the alarm is triggered if any of these readings fall *below* the preset alarm level. All other alarms are triggered if the condition *exceeds* the alarm level value.

Disabling Individual Alarms

Individual alarms may be disabled (and re-enabled) by pressing the **SELECT** key when the relevant alarm is highlighted. The alarm will show ---- to indicate that the alarm is disabled and no further activations of that alarm condition will occur. Press **SELECT** on a disabled alarm to re-enable it.

USER PREFERENCES - PERSONAL TASTES

The following items are available under the *User Preferences Menu*:

- *Backlight mode (Off, On, Automatic)*
- *Temperature units of choice (°C / °F)*
- *Oil pressure units of choice (Bar / PSI)*
- *Fuel units of choice (Litres, US Gal, Imp Gal, kg, Lbs, %)*
- *Fuel Level method (MEASURED / CALCULATED)*
- *Decimal / Minutes option on duration displays (Hobbs / Trip / Maintenance / Endurance)*
- *Trip Timer reset mode (STARTUP / MANUAL)*
- *Hobbs meter minimum revs. Hobbs meters runs when revs exceed this value.*
- *Maintenance count-down timer preset (to warn of scheduled maintenance)*
- *Hobbs meter setting (allowing the engine hours counter to be preset)*



TECHNICAL SETUP

A special *Technical Menu* option becomes available under the *Main Menu* if you press + and - simultaneously after switch-on (while the unit is displaying the *Stratmaster E2* logo. The *Technical Menu* provides various options that are useful during the factory testing and calibration of the instrument.

The items available under this menu may change between releases of the firmware and are not normally used by the user of this instrument. Please do not alter any of the settings as this may adversely affect the operation or accuracy of your instrument.

TECHNICAL SPECIFICATIONS

- Physical Size: 204x92 mm.
- Mounting depth: 75mm (including connectors and wiring).
- Panel cutout: 200x90 mm.
- Weight: 480 grams (Excluding external senders).
- Power supply: 12V DC nominal.
Range 7.5V DC to 28V DC.
Internally protected to 40 V DC.
- Current consumption: 80 mA without backlight, 280 mA with backlight. (includes current consumption of *RDAC IV* unit)
- Rev counter input: High impedance. Accepts signals up to 100V RMS. Maximum frequency 10 KHz. Internally protected against over voltage.
- External temperature: Optimised for National Semiconductor LM335 temperature sender (supplied). Display resolution 1 °C or 1 °F. Accuracy 0.5 degrees typical. Range -50 to +99 °C (-58 °F to 210 °F).
- Thermocouple inputs: Four-channel thermocouple amplifier, high resolution, chopper stabilised system with full cold junction compensation and bow voltage correction to laboratory standards. The inputs can accept K-type or J-type thermocouples (selectable during system setup)
- NTC inputs: Two-channel NTC measurement input for Rotax 912 standard CHT senders. Oil or Water temperature input compatible with Rotax oil temperature sender and MGL water temperature sender. Measurement accuracy +/- 2%, subject to accuracy of sender.
Note: Senders are manufactured with a tolerance of up to +/- 20%.
- Oil pressure input: Accepts most commercial oil pressure senders including the VDO unit used by Rotax. Calibration via menu functions.
- Rev counter input: Universal input can be used on a wide variety of engines (2 or four stroke) using a variety of interface methods (Eg: inductive pickup). Range: 0 to 9999 revs. Resolution is dependent on rev counter setup in instrument. Accuracy: +/- 0.0005% + resolution.
- Fuel flow input: Optimised for RS 256-225 flow sender (optional). Will accept other senders providing a 5-volt TTL output and calibration via menu functions. Accuracy of measurement is +/-0.05% subject to accuracy of fuel flow sender used. Example sender is RS 256-225: +/- 3% uncalibrated, typically less than 1% calibrated.
- Fuel level input: Optimised for standard automotive level senders from 100 to 500 ohms resistance, any slope (increasing resistance with level or decreasing resistance with level) with extensive calibration functions provided to allow direct readout of remaining fuel corrected for tank shape and sender tolerances. Measurement accuracy of input: +/- 2%. Overall measurement accuracy of fuel level is subject to quality and installation of chosen fuel level sender as well as complexity and form of tank shape. Using the prescribed calibration procedure we find we can calibrate within 5% of actual level for most tank shapes.
- Alarm contacts: Uncommitted reed relay output. Recommended not to exceed 500 mA DC current. Maximum voltage 50 volts. Please note: heavy inductive loads must be protected by means of a reverse polarity diode in order to prevent sparks from destroying the reed relay contacts.
- Air-Talk link: Two *Air-Talk* link connectors are provided for *daisy-chaining* to other *Air-Talk* compatible instruments. The *Stratmaster E2* uses the *Air-talk* link to upload the flight data recorder to a remote PC.