

Stratomaster Smart Single

RTC-2

Aviation UTC Real time clock and OAT display



The RTC-2 is a 2.25" format aviation Real Time Clock featuring a two time zone system, stopwatch, countdown timer, alarm and OAT (Outside Air Temperature) display.

It is primarily intended to show UTC time (also known as Greenwich Mean Time, GMT or Zulu time) together with a local time to facilitate ordinary ATC time reporting. Each time zone may be programmed with an additional hour offset to allow for summer time or similar variances. Local offsets may be added or subtracted.

Stopwatch and Timers can be operated simultaneously to a programmable alarm, making the RTC-2 particularly suitable for sport flying competitions.

OAT can be shown in either degrees Celsius or degrees Fahrenheit. The RTC-2 can be setup to alternate between the Time functions and the OAT display.

Time is maintained by an internal 10 year lithium battery which can be replaced by the user.

The Main Display:

The main display can be set up to show UTC time, Stopwatch, Countdown timer, Alarm or OAT. The main display can also be setup to alternate between the Time functions and OAT, giving the user a more versatile instrument.



UTC display showing two independent time zones. The top display is normally used to display UTC time but this can be changed using the "Main time zone" selection



This screen shows the stopwatch. The stopwatch can be started and stopped at any time and reset to zero.



This screen shows the timer. The timer is loaded from a preset value that can be adjusted in the menu. Once loaded, the timer can be started and counts down. It can be stopped and restarted at any time.



This screen shows the alarm time. The alarm time is set in the menu.



This screen shows the OAT (Outside Air Temperature) value. The OAT can be setup in the menu to be displayed in either Degrees Celsius or in Degrees Fahrenheit.

Setting up the RTC-2:

Main Menu ...

```

*** Done ***
Mode: Timer
Disp: Normal
Contrast: 30
Backlight: On
Timer preset
Alarm preset
Set UTC time
Main Time Zone
Local offsets
Temp in: Deg C
Temp Cal: 0

```

Press the Menu key to enter the menu. You can move forward and backwards in the menu by using the + and – keys. To change or select a menu item, move the highlight to the desired item and then press the Menu key. To end an edit or function, press the Menu key again.

To exit the menu and continue normal operation, select the *****Done***** function and press the Menu key. Note, all changes you have initiated during your session will only be remembered by the instrument if you exit the menu using the *****Done***** function.

Technical setup function “Temp Cal” is only accessible if you start up the instrument while pressing both “+” and “-“ buttons at the same time)

Mode: ...

```

*** Done ***
Mode: Timer
Disp: Normal
Contrast: 30

```

This function selects what the main display of the instrument will show during normal run mode.

Display: ...

```

*** Done ***
Mode: Timer
Disp: Normal
Contrast: 30

```

This function selects whether the main display must alternate between the selected time mode above and the OAT.

Contrast: ...

```

*** Done ***
Mode: Timer
Disp: Normal
Contrast: 30

```

This function allows you to change the display contrast to your liking. The contrast can be adjusted from 20 to 45. (Value can vary depending on display type).

Backlight ...

```
Mode: Timer
Disp: Normal
Contrast: 30
Backlight: On
```

This function allows you to switch the display backlight on or off.

Timer Preset

```
Disp: Normal
Contrast: 30
Backlight: On
Timer preset
```

Enter the timer preload value. In the picture it is shown as 5 minutes. This is the value that it loaded into the timer when you perform a timer load. The timer counts down to zero when started, starting from this value.

```
Timer preset
00:05.00
^^
```

Use the + and – keys to adjust the item indicated by the ^^. Use the enter key to move the ^^.

Alarm Preset

```
Contrast: 30
Backlight: On
Timer preset
Alarm preset
```

```
Local time alm
07:54.00
^^
```

Enter the local time that will activate the alarm.
Note: Alarms are based on the time of your selected local time zone

Set UTC time

```
Backlight: On
Timer preset
Alarm preset
Set UTC time
```

This function is used to set the internal real time clock. The time to be entered must be UTC in order for the system to operate correctly. Do not enter local time (unless it is the same as UTC).
UTC is the same as Greenwich Mean Time (GMT) or Zulu time.

```
Enter UTC time
17:02.52
^^
```

Use the + and – keys to adjust the item indicated by the ^^.

Main Time Zone

```
Timer preset
Alarm preset
Set UTC time
Main Time Zone
```

Select the main time zone that is to be displayed on the top section of the display. Normally this should be set to UTC.

```
UTC Zulu
+ Select -
```

Local Offsets

```
Alarm preset
Set UTC time
Main Time Zone
Local offsets
```

Each of the time zones can be individually modified by adding or subtracting one or more hours from its ordinary time.

The picture shows that the London time zone has one hour added. This would set this time zone to “summer time”. Offsets can range from –12 to +12 hours. For normal operation of the time zone this value should be set to zero.

```
London
Offset: 1
```

Use the + and – keys to select the time zone to change. Once you have selected the time zone, press the enter key to highlight the offset value. Now the + and – keys can be used to change the offset value. Press enter key again to end the edit.

Please note that only one time zone can be edited at a time.

Temp In: ...

```
Set UTC time
Main Time Zone
Local offsets
Temp in: Deg C
```

The OAT can be displayed in either degrees Celsius or in degrees Fahrenheit.

Temp Cal: ...

```
Main Time Zone
Local offsets
Temp in: Deg C
Temp Cal: 0
```

This menu item is only available when you power up the unit and simultaneously press the “+” and “-” key. Please use this menu item with care, as changing this value will recalibrate the temperature sensor.

The Stopwatch



Stopwatch is halted.
 Press "+" (GO) to start the stop watch.
 Press "-" (Zero) to set the stop watch to zero



Stopwatch is running.
 Press "-" to halt the stop watch.

The Timer



Timer halted, loaded to 5.00 minutes.
 Press "+" to start the timer.
 Press "-" to load the timer.



Timer running.
 Press "-" to stop the timer

The timer is connected to the external alarm output of the RTC-1.
 The alarm will be activated if the timer reaches 00:00.00. In this case the timer will be shown flashing. Should the display be showing any other function when the timer reaches zero, it will change to display the timer (Menu excluded).
 The external alarm will be deactivated if you press any button.

The Local Time Alarm



You can use the "+" and "-" buttons to enable or disable the alarm. The alarm time is entered in the menu. The alarm time is always "local time". When the local time matches the alarm time, the alarm is activated and the alarm time will flash. Should the display be showing any other function when the alarm activates, it will change to display the alarm time (Menu excluded). The external alarm will be deactivated if you press any button.

Technical specifications:

Display temperature range (operational): -20 to +80 degrees C

Supply voltage: +8 to +18V. +24/28V with optional pre-regulator.

Supply current: 15mA/70mA (backlight off/on)

Display: Graphic LCD with rear green/yellow LED backlight

Weight: 90 grams

Protection: Build in reverse voltage and 33V over voltage protection

Battery type: CR2032

Alarm output: Open collector transistor switch to ground. Maximum rating 0.5A DC only.

Ambient Temperature Sender type: LM335 (National Semiconductor)

Changing the battery.

The RTC-2 maintains an internal Lithium battery to supply power to run the internal clock. This battery typically lasts for up to ten years. If you find the RTC-2 loses time when you switch off main power you should replace the battery. This battery is of type CR2032. It is used in many calculators and similar equipment and is easy to obtain. The battery holder is located on the middle PCB. Observe correct polarity when installing a new battery. The side marked "+" faces towards the back of the RTC-2.

Installing the RTC-2

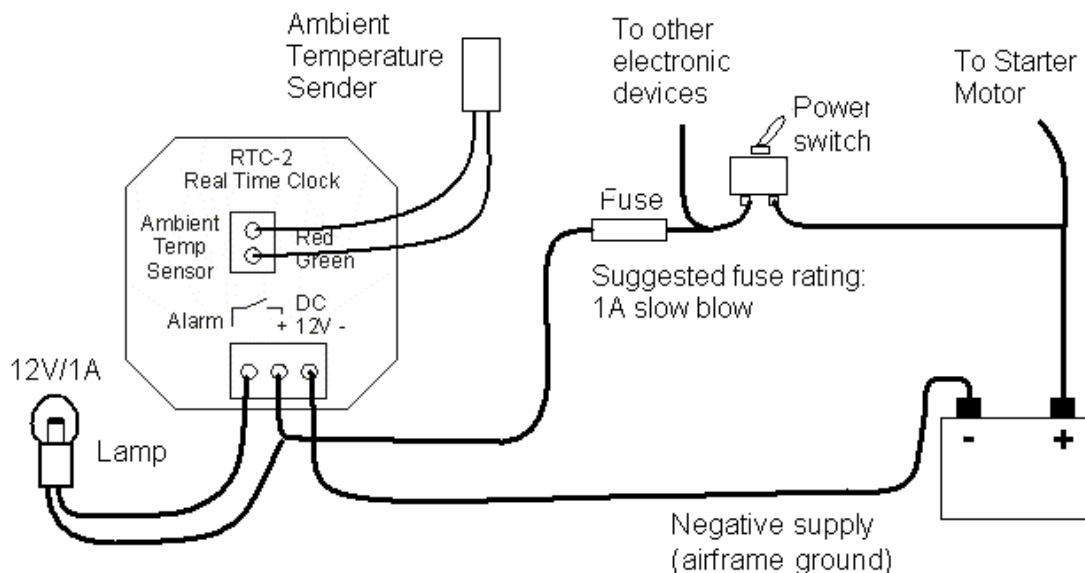

Connect the supply terminals to your aircraft's power supply (you will need a dropping resistor or pre-regulator for 24/28V systems). Install suitable power supply protection if you have a supply that can contain large voltage transients such as can be created by starter motors and solenoids.

Ensure that the supply voltage will not drop below 8V during operation as this may result in incorrect readings.

Make sure the RTC-2 is installed in the same configuration as the above drawing.

The installation of a fuse is highly recommended.

Warranty:

MGL avionics warrants their products for a period of one year from date of purchase against faulty workmanship. Warranty is limited to the replacement of faulty components and includes the cost of labour. Shipping costs are for the account of the purchaser.

Note for operation on supplies with inductive loads:

Any operation of electronic instrumentation on power supplies that are subject to high voltages caused by operation of inductive loads (starter motors, solenoids, relays) are required to be fitted with suitable protection.

The RTC-2 instrument is guaranteed to withstand temporary over voltage up to 33V without additional protection. We recommend that measures are taken to prevent voltage transients in excess of this limit. MGL Avionics recommends the fitment of a fuse in line to protect electronic instruments, radios and intercom systems.

Please note that product warranty excludes damages caused by unprotected, unsuitable or incorrectly wired electrical supplies.

Any signs of opening the instrument or tampering with any of the internal parts will invalidate the warranty.

Disclaimer:

MGL Avionics cannot be held responsible for incidents or damage by whatsoever nature caused by incorrect readings, displays, installation or operation of the instrument.

Operation of the RTC-2 instrument is the responsibility of the pilot in command of the aircraft. The pilot in command has to make himself familiar with the operation and limitations of the RTC-2 instrument before commencing ground or flight operations as well as all other aspects of operation.

The RTC-2 is intended for operation by a licensed pilot who is the holder of a MPL (Micro light pilot license) or PPL (Private Pilot license) or the equivalent thereof. The pilot should further be rated on the aircraft type on which the RTC-2 is being operated.

The RTC-2 has not been submitted to the CAA or FAA or any of its agencies for any form of certification. Operation and installation of this instrument is subject to the relevant rules and regulations of your country and flight authority. If any of the above is not acceptable to the pilot in command then they must refrain from operating the aircraft or remove the RTC-2 from the aircraft before commencing aircraft operations.